

**VACON 10**  
AC DRIVES

# COMPLETE USER MANUAL

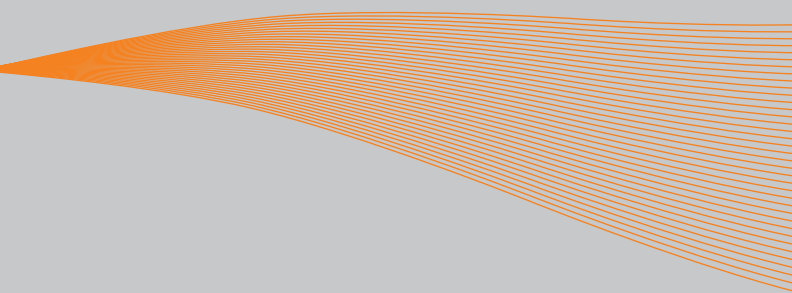

## TABLE OF CONTENTS

Document code: DPD00288B3

Edited: 20.01.2011

<b>1. Safety</b>	<b>4</b>
1.1 Warnings	4
1.2 Safety instructions	6
1.3 Earthing and earth fault protection	6
1.4 Before running the motor	7
<b>2. Receipt of delivery</b>	<b>8</b>
2.1 Type designation code	8
2.2 Storage	8
2.3 Maintenance	8
2.4 Warranty	9
2.5 Manufacturer's declaration of conformity	10
<b>3. Installation</b>	<b>11</b>
3.1 Mechanical installation	11
3.1.1 Vacon 10 dimensions	12
3.1.2 Cooling	13
3.1.3 EMC levels	13
3.1.4 Changing the EMC protection class from C2 or C3 to C4 for IT networks	14
3.2 Cabling and connections	15
3.2.1 Power cabling	15
3.2.2 Control cabling	16
3.2.3 Cable and fuse specifications	18
3.2.4 General cabling rules	21
3.2.5 Stripping lengths of motor and mains cables	22
3.2.6 Cable installation and the UL standards	22
3.2.7 Cable and motor insulation checks	22
<b>4. Commissioning</b>	<b>23</b>
4.1 Commissioning steps of Vacon 10	23
<b>5. Fault tracing</b>	<b>25</b>
<b>6. Vacon 10 Application Interface</b>	<b>28</b>
6.1 Introduction	28
6.2 Control I/O	30

<b>7. Control panel</b>	<b>32</b>
7.1 General	32
7.2 Display	32
7.3 Keypad	33
7.4 Navigation on the Vacon 10 control panel	34
7.4.1 Main menu	34
7.4.2 Reference menu	35
7.4.3 Monitoring menu	36
7.4.4 Parameter menu	38
7.4.5 Fault history menu	39
<b>8. STANDARD application parameters</b>	<b>40</b>
8.1 Quick setup parameters (Virtual menu, shows when par. 13.1 = 1)	41
8.2 Motor settings (Control panel: Menu PAR -> P1)	43
8.3 Start/stop setup (Control panel: Menu PAR -> P2)	44
8.4 Frequency references (Control panel: Menu PAR -> P3)	44
8.5 Ramps and brakes setup (Control panel: Menu PAR -> P4)	45
8.6 Digital inputs (Control panel: Menu PAR -> P5)	45
8.7 Analogue inputs (Control panel: Menu PAR -> P6)	46
8.8 Digital and analogue outputs (Panel: Menu PAR -> P7)	47
8.9 Protections (Control panel: Menu PAR -> P9)	48
8.10 Fault autoreset parameters (Panel: Menu PAR -> P10)	49
8.11 PI control parameters (Control panel: Menu PAR -> P12)	50
8.12 Easy usage menu (Control panel: Menu PAR -> P0)	51
8.13 System parameters	51
<b>9. Parameter descriptions</b>	<b>53</b>
9.1 Motor settings (Control panel: Menu PAR -> P1)	53
9.2 Start/Stop setup (Control panel: Menu PAR -> P2)	58
9.3 Frequency references (Control panel: Menu PAR -> P3)	62
9.4 Ramps & brakes setup (Control panel: Menu PAR -> P4)	63
9.5 Digital inputs (Control panel: Menu PAR -> P5)	67
9.6 Analogue inputs (Control panel: Menu PAR -> P6)	68
9.7 Digital and analogue outputs (Panel: Menu PAR -> P7)	69
9.8 Motor thermal protection (parameters 9.7 - 9.10)	70
9.9 Fault autoreset parameters (Panel: Menu PAR -> P10)	75
9.10 PI control parameters (Control panel: Menu PAR -> P12)	76
9.11 Easy usage menu (Control panel: Menu PAR -> P9)	79
9.11.1 Termination resistor	79
9.11.2 Modbus address area	79
9.11.3 Modbus process data	80

<b>10. Technical data</b>	<b>82</b>
10.1 Vacon 10 technical data	82
10.2 Power ratings	84
10.2.1 Vacon 10 - Mains voltage 115 V	84
10.2.2 Vacon 10 - Mains voltage 208 - 240 V	84
10.2.3 Vacon 10 - Mains voltage 380 - 480 V	85
10.2.4 Vacon 10 - Mains voltage 575 V	86
10.3 Brake resistors	86

## 1. SAFETY



## ONLY A COMPETENT ELECTRICIAN IS ALLOWED TO CARRY OUT THE ELECTRICAL INSTALLATION!

This manual contains clearly marked cautions and warnings which are intended for your personal safety and to avoid any unintentional damage to the product or connected appliances.

**Please read the information included in cautions and warnings carefully:**

	<p><b>= Dangerous voltage</b> Risk of death or severe injury</p>
	<p><b>= General warning</b> Risk of damage to the product or connected appliances</p>

## 1.1 Warnings



The components of the power unit of the frequency converter are live when Vacon 10 is connected to mains. Coming into contact with this voltage is extremely dangerous and may cause death or severe injury. The control unit is isolated from the mains potential.



The motor terminals U, V, W (T1, T2, T3) and the possible brake resistor terminals -/+ are live when Vacon 10 is connected to mains, even if the motor is not running.



The control I/O-terminals are isolated from the mains potential. However, the relay output terminals may have a dangerous control voltage present even when Vacon 10 is disconnected from mains.



The earth leakage current of Vacon 10 frequency converters exceeds 3.5mA AC. According to standard EN61800-5-1, a reinforced protective ground connection must be ensured.



If the frequency converter is used as a part of a machine, the machine manufacturer is responsible for providing the machine with a main switch [EN 60204-1].



If Vacon 10 is disconnected from mains while running the motor, it remains live if the motor is energized by the process. In this case the motor functions as a generator feeding energy to the frequency converter.



After disconnecting the frequency converter from the mains, wait until the fan stops and the indicators on the display go out. Wait 5 more minutes before doing any work on Vacon 10 connections.



The motor can start automatically after a fault situation, if the autoreset function has been activated

## 1.2 Safety instructions



The Vacon 10 frequency converter has been designed for fixed installations only.



Do not perform any measurements when the frequency converter is connected to the mains.



Do not perform any voltage withstand tests on any part of Vacon 10. The product safety is fully tested at factory.



Prior to measurements on the motor or the motor cable, disconnect the motor cable from the frequency converter.



Do not open the cover of Vacon 10. Static voltage discharge from your fingers may damage the components. Opening the cover may also damage the device. If the cover of Vacon 10 is opened, warranty becomes void.

## 1.3 Earthing and earth fault protection

The Vacon 10 frequency converter **must always** be earthed with an earthing conductor connected to the earthing terminal. See figure below:

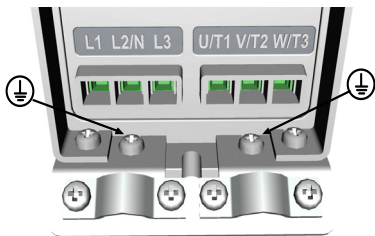

- The earth fault protection inside the frequency converter protects only the converter itself against earth faults.
- If fault current protective switches are used they must be tested with the drive with earth fault currents that are possible to arise in fault situations.

## 1.4 Before running the motor

*Checklist:*



Before starting the motor, check that the motor is mounted properly and ensure that the machine connected to the motor allows the motor to be started.



Set the maximum motor speed (frequency) according to the motor and the machine connected to it.



Before reversing the motor shaft rotation direction make sure that this can be done safely.



Make sure that no power correction capacitors are connected to the motor cable.



## 2. RECEIPT OF DELIVERY

After unpacking the product, check that no signs of transport damages are to be found on the product and that the delivery is complete (compare the type designation of the product to the code below).

Should the drive have been damaged during the shipping, please contact primarily the cargo insurance company or the carrier.

If the delivery does not correspond to your order, contact the supplier immediately.

### 2.1 Type designation code

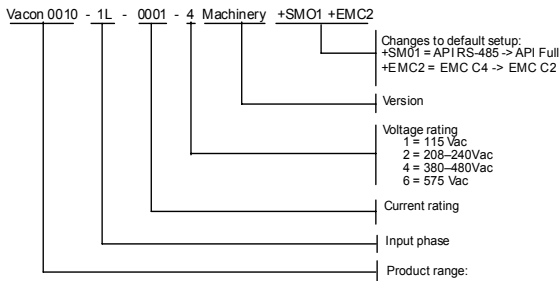

Figure 2.1: Vacon 10 type designation code

### 2.2 Storage

If the frequency converter is to be kept in store before use make sure that the ambient conditions are acceptable:

Storing temperature -40...+70°C

Relative humidity < 95%, no condensation

### 2.3 Maintenance

In normal operating conditions, Vacon 10 frequency converters are maintenance-free.

## 2.4 Warranty

Only manufacturing defects are covered by the warranty. The manufacturer assumes no responsibility for damages caused during or resulting from transport, receipt of the delivery, installation, commissioning or use.

The manufacturer shall in no event and under no circumstances be held responsible for damages and failures resulting from misuse, wrong installation, unacceptable ambient temperature, dust, corrosive substances or operation outside the rated specifications. Neither can the manufacturer be held responsible for consequential damages.

The Manufacturer's time of warranty is 18 months from the delivery or 12 months from the commissioning whichever expires first (General Conditions NL92/Orgalime S92).

The local distributor may grant a warranty time different from the above. This warranty time shall be specified in the distributor's sales and warranty terms. Vacon assumes no responsibility for any other warranties than that granted by Vacon itself.

In all matters concerning the warranty, please contact first your distributor.

## 2.5 Manufacturer's declaration of conformity



## EU DECLARATION OF CONFORMITY

We

**Manufacturer's name:** Vacon Oyj  
**Manufacturer's address:** P.O.Box 25  
Runsorintie 7  
FIN-65381 Vaasa  
Finland

hereby declare that the product

**Product name:** Vacon 10 Frequency Converter

**Model designation:** Vacon 10 1L 0001 1...to 1L 0005 1  
Vacon 10 1L 0001 2...to 1L 0009 2  
Vacon 10 3L 0001 2...to 3L 0011 2  
Vacon 10 3L 0001 4...to 3L 0012 4  
Vacon 10 3L 0002 6...to 1L 0011 6

has been designed and manufactured in accordance with the following standards:

**Safety:** EN 61800-5-1 (2003)

**EMC:** EN 61800-3 (2004)

and conforms to the relevant safety provisions of the Low Voltage

Directive

2006/95/EC and EMC Directive 2004/108/EC.

It is ensured through internal measures and quality control that the product conforms at all times to the requirements of the current Directive and the relevant standards.

In Vaasa, 6th of May, 2008

Vesa Laisi  
President

### 3. INSTALLATION

#### 3.1 Mechanical installation

There are two possible ways to mount Vacon 10 in the wall; either screw or DIN-rail mounting. The mounting dimensions are given on the back of the drive and on the following page.

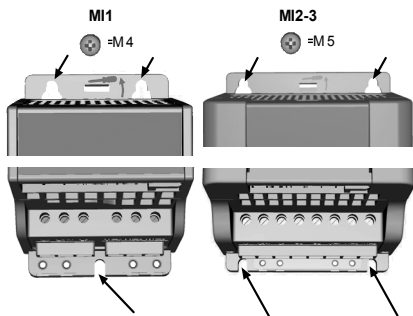

Figure 3.2: Screw mounting

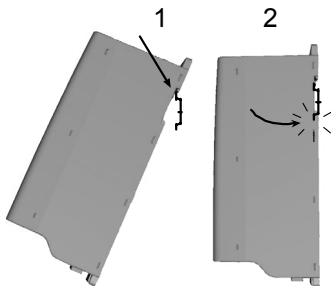

Figure 3.3: DIN-rail mounting

3.1.1 Vacon 10 dimensions

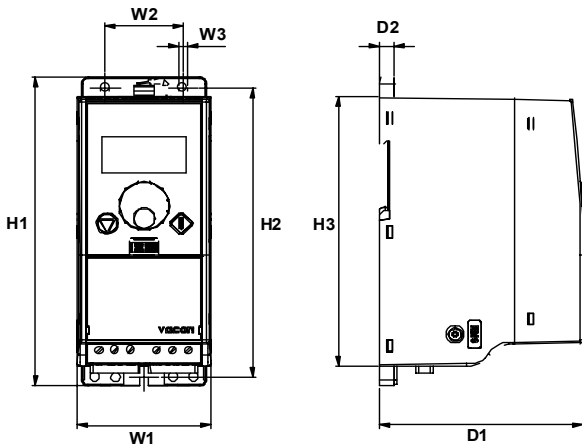

Figure 3.4: Vacon 10 dimensions, MI1-MI3

Type	H1	H2	H3	W1	W2	W3	D1	D2
MI1	160,1	147	137,3	65,5	37,8	4,5	98,5	7
MI2	195	183	170	90	62,5	5,5	101,5	7
MI3	254,3	244	229,3	100	75	5,5	108,5	7

Table 3.1: Vacon 10 dimensions in millimetres

### 3.1.2 Cooling

Forced air flow cooling is used in all Vacon 10 drives.

Enough free space shall be left above and below the frequency converter to ensure sufficient air circulation and cooling. You will find the required dimensions for free space in the table below:

Type	Dimensions (mm)	
	A	B
M11	100	50
M12	100	50
M13	100	50

Table 3.2: Dimensions required for cooling

Type	Cooling air required (m <sup>3</sup> /h)
M11	10
M12	10
M13	30

Table 3.3: Required cooling air

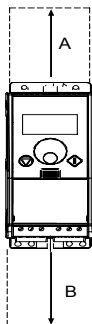

**NOTE!** See the mounting dimensions on the back of the drive.

Leave **free space** for cooling above (**100 mm**), below (**50 mm**), and on the sides (**10 mm**) of Vacon 10! (Side-to-side installation allowed only if the ambient temperature is below 40°C).

### 3.1.3 EMC levels

EN61800-3 defines the division of frequency converters into five classes according to the level of electromagnetic disturbances emitted, the requirements of a power system network and the installation environment (see below). The EMC class of each product is defined in the type designation code.

**Category C1:** Frequency converters of this class comply with the requirements of category C1 of the product standard EN 61800-3 (2004). Category C1 ensures the best EMC characteristics and it includes converters the rated voltage of which is less than 1000V and which are intended for use in the 1st environment. NOTE: The requirements of class C are fulfilled only as far as the conducted emissions are concerned.

**Category C2:** Frequency converters of this class comply with the requirements of category C2 of the product standard EN 61800-3 (2004). Category C2 includes converters in fixed installations and the rated voltage of which is less than 1000V. The class C2 frequency converters can be used both in the 1st and the 2nd environment.

**Category C3:** Frequency converters of this class comply with the requirements of category C3 of the product standard EN 61800-3 (2004). Category C3 includes converters the rated voltage of which is less than 1000V and which are intended for use in the second environment only.

**Category C4:** The drives of this class do not provide EMC emission protection. These kinds of drives are mounted in enclosures.

**Category C4 for IT networks:** Frequency converters of this class fulfil the product standard EN 61800-3 (2004) if intended to be used in IT systems. In IT systems, the networks are isolated from earth, or connected to earth through high impedance to achieve a low leakage current. NOTE: if converters are used with other supplies, no EMC requirements are complied with.

#### *Environments in product standard EN 61800-3 (2004)*

**First environment:** Environment that includes domestic premises. It also includes establishments directly connected without intermediate transformers to a low-voltage power supply network which supplies buildings used for domestic purposes.

NOTE: houses, apartments, commercial premises or offices in a residential building are examples of first environment locations.

**Second environment:** Environment that includes all establishments other than those directly connected to a low-voltage power supply network which supplies buildings used for domestic purposes.

NOTE: industrial areas, technical areas of any building fed from a dedicated transformer are examples of second environment locations.

#### **3.1.4 Changing the EMC protection class from C2 or C3 to C4 for IT networks**

The EMC protection class of Vacon 10 frequency converters can be changed from class C2 or C3 to class C4 for IT networks by **removing the EMC-capacitor disconnecting screw**, see figure below.

**Note!** Do not attempt to change the EMC level back to class C2 or C3. Even if the procedure above is reversed, the frequency converter will no longer fulfil the EMC requirements of class C2/C3!

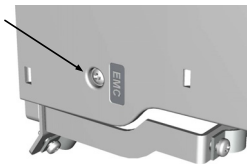

### 3.2 Cabling and connections

#### 3.2.1 Power cabling

**Note!** Tightening torque for power cables is 0.5 - 0.6 Nm

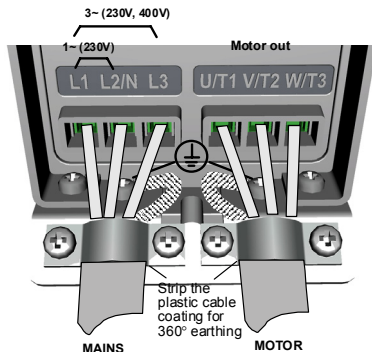

Figure 3.5: Vacon 10 power connections, MI1

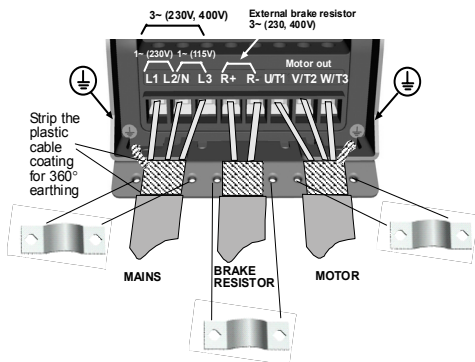

Figure 3.6: Vacon 10 power connections, MI2 - MI3



### 3.2.2 Control cabling

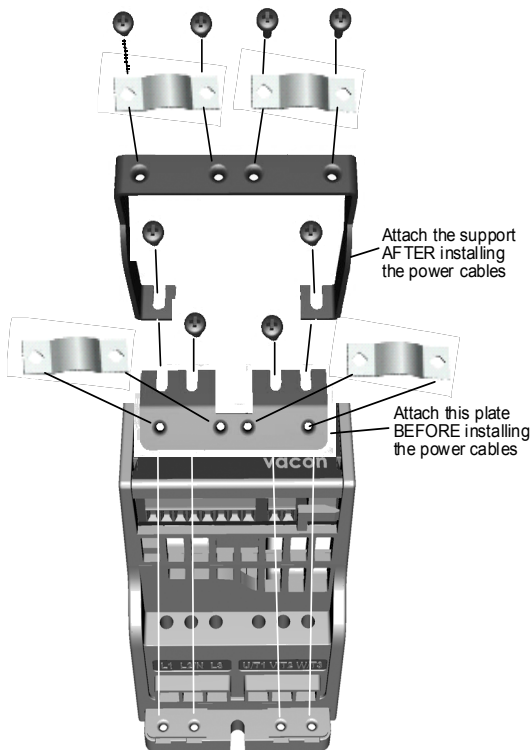

Figure 3.7: Mount the PE- plate and API cable support

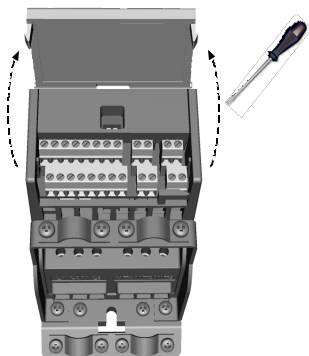

Figure 3.8: Open the lid

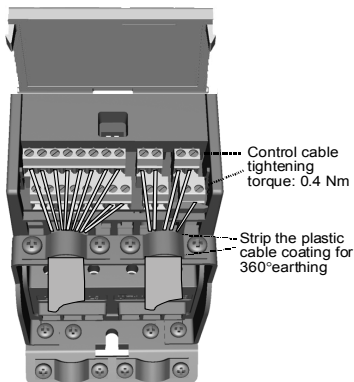

Figure 3.9: Install the control cables. See Chapter 6.3

### 3.2.3 Cable and fuse specifications

Use cables with heat resistance of at least +70 C. The cables and the fuses must be dimensioned according to the tables below. Installation of cables according to UL regulations is presented in Chapter 3.2.6.

The fuses function also as cable overload protection.

These instructions apply only to cases with one motor and one cable connection from the frequency converter to the motor. In any other case, ask the factory for more information.

EMC category	cat. C2	cat. C3	cat. C4
Mains cable types	1	1	1
Motor cable types	3	2	1
Control cable types	4	4	4

Table 3.4: Cable types required to meet standards. EMC categories are described in Chapter 3.1.3.

Cable type	Description
1	Power cable intended for fixed installation and the specific mains voltage. Shielded cable not required. (NKCABLES/MCMK or similar recommended)
2	Power cable equipped with concentric protection wire and intended for the specific mains voltage. (NKCABLES /MCMK or similar recommended).
3	Power cable equipped with compact low-impedance shield and intended for the specific mains voltage. (NKCABLES /MCCMK, SAB/ÖZCUY-J or similar recommended). *360° earthing of both motor and FC connection required to meet the standard
4	Screened cable equipped with compact low-impedance shield (NKCABLES /Jamak, SAB/ÖZCuY-0 or similar).

Table 3.5: Cable type descriptions

Frame	Type	Fuse [A]	Mains cable Cu [mm <sup>2</sup> ]	Motor cable Cu [mm <sup>2</sup> ]	Terminal cable size (min/max)			
					Main terminal [mm <sup>2</sup> ]	Earth terminal [mm <sup>2</sup> ]	Control terminal [mm <sup>2</sup> ]	Relay terminal [mm <sup>2</sup> ]
MI2	0001-0004	20	2*2.5+2.5	3*1.5+1.5	1.5-4	1.5-4	0.5-1.5	0.5-1.5
MI3	0005	20	2*2.5+2.5	3*1.5+1.5	1.5-4	1.5-4	0.5-1.5	0.5-1.5

Table 3.6: Cable and fuse sizes for Vacon 10, 115V, 1~

Frame	Type	Fuse [A]	Mains cable Cu [mm <sup>2</sup> ]	Motor cable Cu [mm <sup>2</sup> ]	Terminal cable size (min/max)			
					Main terminal [mm <sup>2</sup> ]	Earth terminal [mm <sup>2</sup> ]	Control terminal [mm <sup>2</sup> ]	Relay terminal [mm <sup>2</sup> ]
<b>208 - 240V, 1~</b>								
MI1	0001-0004	10	2*1.5+1.5	3*1.5+1.5	1.5-4	1.5-4	0.5-1.5	0.5-1.5
MI2	0005-0007	20	2*2.5+2.5	3*1.5+1.5	1.5-4	1.5-4	0.5-1.5	0.5-1.5
MI3	0009	32	2*6+6	3*1.5+1.5	1.5-6	1.5-6	0.5-1.5	0.5-1.5
<b>208 - 240V, 3~</b>								
MI1	0001-0003	6	3*1.5+1.5	3*1.5+1.5	1.5-4	1.5-4	0.5-1.5	0.5-1.5
MI2	0004-0007	10	3*1.5+1.5	3*1.5+1.5	1.5-4	1.5-4	0.5-1.5	0.5-1.5
MI3	0011	20	3*2.5+2.5	3*2.5+2.5	1.5-6	1.5-6	0.5-1.5	0.5-1.5

Table 3.7: Cable and fuse sizes for Vacon 10, 208 - 240V, 1~ and 3~

Frame	Type	Fuse [A]	Mains cable Cu [mm <sup>2</sup> ]	Motor cable Cu [mm <sup>2</sup> ]	Terminal cable size (min/max)			
					Main terminal [mm <sup>2</sup> ]	Earth terminal [mm <sup>2</sup> ]	Control terminal [mm <sup>2</sup> ]	Relay terminal [mm <sup>2</sup> ]
MI1	0001-0003	6	3*1.5+1.5	3*1.5+1.5	1.5-4	1.5-4	0.5-1.5	0.5-1.5
MI2	0004-0006	10	3*1.5+1.5	3*1.5+1.5	1.5-4	1.5-4	0.5-1.5	0.5-1.5
MI3	0008-0012	20	3*2.5+2.5	3*2.5+2.5	1.5-6	1.5-6	0.5-1.5	0.5-1.5

Table 3.8: Cable and fuse sizes for Vacon 10, 380 - 480V, 3~

Frame	Type	Fuse [A]	Mains cable Cu [mm <sup>2</sup> ]	Motor cable Cu [mm <sup>2</sup> ]	Terminal cable size (min/max)			
					Main terminal [mm <sup>2</sup> ]	Earth terminal [mm <sup>2</sup> ]	Control terminal [mm <sup>2</sup> ]	Relay terminal [mm <sup>2</sup> ]
MI3	0002-0004	6	3*1.5+1.5	3*1.5+1.5	1.5-4	1.5-4	0.5-1.5	0.5-1.5
MI3	0005-0006	10	3*1.5+1.5	3*1.5+1.5	1.5-4	1.5-4	0.5-1.5	0.5-1.5
MI3	0009	20	3*2.5+2.5	3*2.5+2.5	1.5-6	1.5-6	0.5-1.5	0.5-1.5

Table 3.9: Cable and fuse sizes for Vacon 10, 575V

**Note!** To fulfil standard EN61800-5-1, the protective conductor should be **at least 10mm<sup>2</sup> Cu or 16mm<sup>2</sup> Al**. Another possibility is to use an additional protective conductor of at least the same size as the original one.

## 3.2.4 General cabling rules

<b>1</b>	Before starting the installation, check that none of the components of the frequency converter is live.
<b>2</b>	Place the motor cables sufficiently far from other cables: <ul style="list-style-type: none"> <li>• <b>Avoid</b> placing the motor cables in long <b>parallel lines</b> with other cables</li> <li>• If the motor cable runs in parallel with other cables, the <b>minimum distance</b> between the motor cable and other cables is <b>0,3 m</b>.</li> <li>• The given distance also applies between the motor cables and signal cables of other systems.</li> <li>• The <b>maximum length</b> of the motor cables is <b>30 m</b></li> <li>• The <b>motor cables</b> should cross other cables at an angle of <b>90 degrees</b>.</li> </ul>
<b>3</b>	If cable insulation checks are needed, see Chapter 3.2.7.
<b>4</b>	Connecting the cables: <ul style="list-style-type: none"> <li>• Strip the motor and mains cables as advised in Figure 3.10.</li> <li>• Connect the mains, motor and control cables into their respective terminals, see Figures 3.5 - 3.9.</li> <li>• Note the tightening torques of <b>power cables and control cables</b> given in page 15 and page 17.</li> <li>• For information on cable installation according to UL regulations see Chapter 3.2.6 .</li> <li>• Make sure that the control cable wires do not come in contact with the electronic components of the unit</li> <li>• If an <b>external brake resistor</b> [option] is used, connect its cable to the appropriate terminal.</li> <li>• <b>Check the connection</b> of the earth cable to the motor and the frequency converter terminals marked with</li> <li>• Connect the <b>separate shield of the motor cable to the earth plate</b> of the frequency converter, motor and the supply centre</li> </ul>

### 3.2.5 Stripping lengths of motor and mains cables

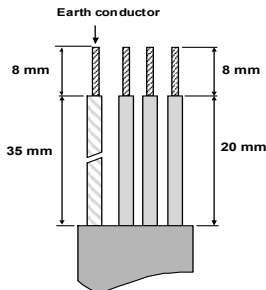

Figure 3.10: Stripping of cables

**Note!** Strip also the plastic cover of the cables for 360 degree earthing. See Figures 3.5, 3.6 and 3.9.

### 3.2.6 Cable installation and the UL standards

To meet the UL (Underwriters Laboratories) regulations, a UL-approved copper cable with a minimum heat-resistance of +60/75 C must be used.

### 3.2.7 Cable and motor insulation checks

These checks can be performed as follows if motor or cable insulations are suspected to be faulty.

#### 1. Motor cable insulation checks

Disconnect the motor cable from terminals U/T1, V/T2 and W/T3 of the frequency converter and from the motor. Measure the insulation resistance of the motor cable between each phase conductor as well as between each phase conductor and the protective ground conductor.

The insulation resistance must be >1MΩm.

#### 2. Mains cable insulation checks

Disconnect the mains cable from terminals L1, L2/N and L3 of the frequency converter and from the mains. Measure the insulation resistance of the mains cable between each phase conductor as well as between each phase conductor and the protective ground conductor. The insulation resistance must be >1MΩm.

#### 3. Motor insulation checks

Disconnect the motor cable from the motor and open the bridging connections in the motor connection box. Measure the insulation resistance of each motor winding. The measurement voltage must equal at least the motor nominal voltage but not exceed 1000 V. The insulation resistance must be >1MΩm.

## 4. COMMISSIONING

Before commissioning, note the warnings and instructions listed in Chapter 1!

## 4.1 Commissioning steps of Vacon 10

<b>1</b>	Read carefully the safety instructions in Chapter 1 and follow them.
<b>2</b>	<p>After the installation, make sure that:</p> <ul style="list-style-type: none"> <li>• both the frequency converter and the motor are grounded</li> <li>• the mains and motor cables comply with the requirements given in Chapter 3.2.3</li> <li>• the control cables are located as far as possible from the power cables (see Chapter , step 2) and the shields of the shielded cables are connected to protective earth</li> </ul> <div style="text-align: center;">  </div>
<b>3</b>	Check the quality and quantity of cooling air (Chapter 3.1.2)
<b>4</b>	Check that all Start/Stop switches connected to the I/O terminals are in <b>Stop</b> -position.
<b>5</b>	Connect the frequency converter to mains
<b>Note: The following steps are valid if you have API Full or API Limited Application Interface in your Vacon 10.</b>	
<b>6</b>	<p>Set the parameters of group 1 according to the requirements of your application. At least the following parameters should be set:</p> <ul style="list-style-type: none"> <li>• motor nominal voltage (par. 1.1)</li> <li>• motor nominal frequency (par. 1.2)</li> <li>• motor nominal speed (par. 1.3)</li> <li>• motor nominal current (par. 1.4)</li> </ul> <p>You will find the values needed for the parameters on the motor rating plate</p>



7	<p>Perform test run <b>without motor</b>. Perform either Test A or Test B:</p> <p><b>A)</b> Control from the I/O terminals:</p> <ul style="list-style-type: none"><li>• Turn the Start/Stop switch to ON position.</li><li>• Change the frequency reference (potentiometer)</li><li>• Check in the Monitoring Menu that the value of Output frequency changes according to the change of frequency reference.</li><li>• Turn the Start/Stop switch to OFF position</li></ul> <p><b>B)</b> Control from the keypad:</p> <ul style="list-style-type: none"><li>• Select the keypad as the control place with <b>par 2.5</b>. You can also move to keypad control by pressing the navigation wheel for 5 seconds.</li><li>• Push the Start button on the keypad</li><li>• Check in the Monitoring Menu that the value of Output frequency changes according to the change of frequency reference</li><li>• Push the Stop button on the keypad</li></ul>
8	<p>Run the no-load tests without the motor being connected to the process, if possible. If this is not possible, secure the safety of each test prior to running it. Inform your co-workers of the tests.</p> <ul style="list-style-type: none"><li>• Switch off the supply voltage and wait up until the drive has stopped.</li><li>• Connect the motor cable to the motor and to the motor cable terminals of the frequency converter.</li><li>• See to that all Start/Stop switches are in Stop positions.</li><li>• Switch the mains ON</li><li>• Repeat test 7A or 7B</li></ul>
9	<p>Perform an identification run (see par. 1.18), especially if the application requires a high startup torque or a high torque with low speed.</p>
10	<p>Connect the motor to the process (if the no-load test was run without the motor being connected)</p> <ul style="list-style-type: none"><li>• Before running the tests, make sure that this can be done safely.</li><li>• Inform your co-workers of the tests.</li><li>• Repeat test 7A or 7B.</li></ul>

## 5. FAULT TRACING

**Note:** The fault codes listed in this chapter are visible if the Application Interface has a display, like e.g. in API FULL or API LIMITED or if a personal computer has been connected to the drive

When a fault is detected by the frequency converter control electronics, the drive is stopped and the symbol F together with the ordinal number of the fault and the fault code appear on the display in the following format, e.g:

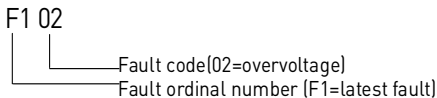

The fault can be reset by pressing the Stop button on the control keypad or via the I/O terminal or fieldbus. The faults with time labels are stored in the Fault history menu which can be browsed. The different fault codes, their causes and correcting actions are presented in the table below.

Fault code	Fault name	Possible cause	Correcting actions
1	Overcurrent	Frequency converter has detected too high a current ( $>4 \cdot I_N$ ) in the motor cable: <ul style="list-style-type: none"> <li>• sudden heavy load increase</li> <li>• short circuit in motor cables</li> <li>• unsuitable motor</li> </ul>	Check loading. Check motor size. Check cables.
2	Overvoltage	The DC-link voltage has exceeded the internal safety limit: <ul style="list-style-type: none"> <li>• too short a deceleration time</li> <li>• high overvoltage spikes in mains</li> </ul>	Increase the deceleration time (P.4.3)
3	Earth fault	Current measurement has detected extra leakage current at start: <ul style="list-style-type: none"> <li>• insulation failure in cables or motor</li> </ul>	Check motor cables and motor

Table 5.10: Fault codes

Fault code	Fault name	Possible cause	Correcting actions
8	System fault	<ul style="list-style-type: none"> <li>• component failure</li> <li>• faulty operation</li> </ul>	Reset the fault and restart. Should the fault re-occur, contact the distributor near to you <b>NOTE!</b> If fault F8 occurs, find out the subcode of the fault from the Fault History menu under M (minutes)!
9	Undervoltage	The DC-link voltage has gone below the internal safety limit: <ul style="list-style-type: none"> <li>• most probable cause: too low a supply voltage</li> <li>• frequency converter internal fault</li> <li>• Power outages</li> </ul>	In case of temporary supply voltage break reset the fault and restart the frequency converter. Check the supply voltage. If it is adequate, an internal failure has occurred. Contact the distributor near to you
11	Output phase supervision	Current measurement has detected that there is no current in one motor phase	Check motor cable and motor
13	Frequency converter undertemperature	Heat sink temperature is under -10 C	Check the ambient temperature
14	Frequency converter overtemperature	Heat sink is overheated.	Check that the cooling air flow is not blocked. Check the ambient temperature. Make sure that the switching frequency is not too high in relation to ambient temperature and motor load.
15	Motor stalled	Motor stall protection has tripped	Check that the motor is able to rotate freely
16	Motor overtemperature	Motor overheating has been detected by frequency converter motor temperature model. Motor is overloaded	Decrease the motor load. If no motor overload exists, check the temperature model parameters.
17	Motor underload	Motor underload protection has tripped	Check motor and load, e.g. for broken belts or dry pumps

Table 5.10: Fault codes

Fault code	Fault name	Possible cause	Correcting actions
22	EEPROM checksum fault	Parameter save fault <ul style="list-style-type: none"> <li>• faulty operation</li> <li>• component failure</li> </ul>	Contact the distributor near to you
25	Microcontroller watchdog fault	<ul style="list-style-type: none"> <li>• faulty operation</li> <li>• component failure</li> </ul>	Reset the fault and restart. Should the fault re-occur, contact the distributor near to you.
27	Back EMF protection	Drive has detected that the magnetized motor is running in start situation <ul style="list-style-type: none"> <li>• A rotating PM-motor</li> </ul>	Make sure that there is no rotating PM-motor when the start command is given.
34	Internal bus communication	Ambient interference or defective hardware	Should the fault re-occur, contact the distributor near to you.
35	Application fault	Application is not working properly	Contact the distributor near to you
41	IGBT Overtemperature	Overtemperature alarm is issued when the IGBT switch temperature exceeds 110 °C	Check loading. Check motor size. Make identification run.
50	Analogue input $I_{in} < 4\text{mA}$ (selected signal range 4 to 20 mA)	Current at the analogue input is $< 4\text{mA}$ <ul style="list-style-type: none"> <li>• control cable is broken or loose</li> <li>• signal source has failed</li> </ul>	Check the current loop circuitry
51	External fault	Digital input fault. Digital input has been programmed as external fault input and this input is active.	
53	Fieldbus fault	The data connection between the fieldbus Master and the fieldbus of the drive broken	Check installation. If installation is correct contact the nearest Vacon distributor.
57	Identification fault	Identification run has failed.	Run command was removed before completion of identification run. Motor is not connected to frequency converter. There is load on motor shaft

Table 5.10: Fault codes

## 6. VACON 10 APPLICATION INTERFACE

### 6.1 Introduction

There are three versions of Application Interfaces (API) available for the Vacon 10 drive:

API Full	API Limited	API RS-485 (Modbus RTU)
6 Digital inputs	3 Digital inputs	1 Digital input
2 Analogue inputs	1 Analogue input	1 Relay output
1 Analogue output	1 Relay output	RS-485 Interface
1 Digital output	RS-485 Interface	
2 Relay outputs		
RS-485 Interface		

Table 6.1: Available Application Interfaces

This section provides you with a description of the I/O-signals for these versions and instructions for using the Vacon 10 general purpose application.

The frequency reference can be selected from the analogue inputs, fieldbus, preset speeds or keypad.

#### Basic properties:

- Digital inputs DI1...DI6 are freely programmable. The user can assign a single input to many functions
- Digital-, relay- and analogue outputs are freely programmable
- Analogue input 1 can be programmed as current or voltage input in API Limited version

#### Special features in all API versions:

- Programmable Start/Stop and Reverse signal logic
- Reference scaling.
- Programmable start and stop functions
- DC-brake at start and stop
- Programmable U/f curve
- Adjustable switching frequency
- Autoreset function after fault
- Protections and supervisions (all fully programmable; off, alarm, fault):

- Current signal input fault
- External fault
- Undervoltage fault
- Earth fault
- Motor thermal, stall and underload protection
- Fieldbus communication

*Special features in API Full and API Limited:*

- 8 preset speeds
- Analogue input range selection, signal scaling and filtering
- PI-controller

## 6.2 Control I/O

Reference

Potentiometer: 1- 10K +/- 5%

## API FULL

Terminal	Signal	Factory preset	Description
1	+10Vre	Ref. voltage out	Maximum load 10 mA
2	AI1	Analog signal in 1	Freq. reference <sup>PI</sup> 0 - +10 V Ri = 200 kΩ (min)
3	GND	I/O signal ground	
6	24Vout	24V output for DI's	±20 %, max. load 50 mA
7	GND	I/O signal ground	
8	DI1	Digital input 1	Start forward <sup>PI</sup> 0 - +30 V Ri = 12 kΩmin
9	DI2	Digital input 2	Start reverse <sup>PI</sup>
10	DI3	Digital input 3	Preset speed B0 <sup>PI</sup>
A	A	RS485 signal A	FB Communication Positive
B	B	RS485 signal B	FB Communication Negative
4	AI2	Analog signal in 2	PI actual value <sup>PI</sup> 0(4) - 20 mA, Ri = 200Ω
5	GND	I/O signal ground	
13	GND	I/O signal ground	
14	DI4	Digital input 4	Preset speed B1 <sup>PI</sup>
15	DI5	Digital input 5	Fault reset <sup>PI</sup>
16	DI6	Digital input 6	Disable PI contr. <sup>PI</sup>
18	AO	Output frequency <sup>PI</sup>	0(4) - 20 mA, RL = 500Ω
20	DO	Digital signal out	Active = READY <sup>PI</sup> Open collector, max. load 48V/50mA
22	RO 13	Relay out 1	Active = RUN <sup>PI</sup> Max. switching load: 250Vac/2A or 250Vdc/ 0,4A
23	RO 14		
24	RO 22	Relay out 2	Active = FAULT <sup>PI</sup> Max. switching load: 250Vac/2A or 250Vdc/ 0,4A
25	RO 21		
26	RO 24		

Table 6.2: Vacon 10 General purpose application default I/O configuration and connections for API FULL version

<sup>PI</sup>) = Programmable function, see parameter lists and descriptions, chapters 8 and 9.

## API LIMITED

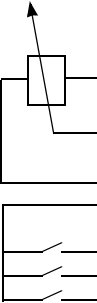

Terminal	Signal	Factory preset	Description
1	+10Vre	Ref. voltage out	Maximum load 10 mA
2	AI1	Analog signal in 1	Freq. reference <sup>P1</sup> Can be changed to 0(4)mA - 20mA current input with the dip switch [see ch. 9.12.1]
3	GND	I/O signal ground	
6	24Vout	24V output for DI's	±20 %, max. load 50 mA
7	GND	I/O signal ground	
8	DI1	Digital input 1	Start forward <sup>P1</sup>
9	DI2	Digital input 2	Start reverse <sup>P1</sup>
10	DI3	Digital input 3	Preset speed B0 <sup>P1</sup>
A	A	RS485 signal A	FB Communication
B	B	RS485 signal B	FB Communication
24	RO 22	Relay out 2	ACTIVE (Relay opened) = FAULT <sup>P1</sup>
25	RO 21		

Table 6.3: Vacon 10 General purpose application default I/O configuration and connections for API LIMITED version  
 P) = Programmable function, parameter lists and descriptions, chapters 8 and 9.

## API RS-485



Terminal	Signal	Factory preset	Description
3	GND	I/O signal ground	
6	24Vout	24V output for DI's	±20 %, max. load 50 mA
7	GND	I/O signal ground	
8	DI1	Digital input 1	1 = Start forward
A	A	RS485 signal A	FB Communication
B	B	RS485 signal B	FB Communication
24	RO 22	Relay out 2	ACTIVE (Relay opened) = FAULT <sup>P1</sup>
25	RO 21		

Table 6.4: Vacon 10 General purpose application default I/O configuration and connections for API RS-485 version  
 P) = Programmable function, parameter lists and descriptions, chapters 8 and 9.



## 7. CONTROL PANEL

### 7.1 General

The Vacon 10 API Full and API Limited versions have similar control panels. The panel is integrated to the drive consisting of corresponding application card and an overlay on the drive cover with status display and button clarifications.

The Control panel consists of an LCD display with backlight and a keypad including a navigation wheel, a green START button and a red STOP button (see Figure 7.11).

### 7.2 Display

The display includes 14-segment and 7-segment blocks, arrowheads and clear text unit symbols. The arrowheads, when visible, indicate some information about the drive, which is printed in clear text on the overlay (numbers 1...14 in the figure below). The arrowheads are grouped in 3 groups with the following meanings and English overlay texts (see Figure 7.11):

#### *Group 1 - 5; Drive status*

- 1= Drive is ready to start (READY)
- 2= Drive is running (RUN)
- 3= Drive has stopped (STOP)
- 4= Alarm condition is active (ALARM)
- 5= Drive has stopped due to a fault (FAULT)

#### *Group 6 - 10; Control selections*

- 6= Motor is rotating forward (FWD)
- 7= Motor is rotating reverse (REV)
- 8= I/O terminal block is the selected control place (I/O)
- 9= Keypad is the selected control place (KEYPAD)
- 10= Fieldbus is the selected control place (BUS)

#### *Group 11 - 14; Navigation main menu*

- 11= Reference main menu (REF)
- 12= Monitoring main menu (MON)
- 13= Parameter main menu (PAR)
- 14= Fault history main menu (FLT)



Figure 7.11: Vacon 10 Control panel

### 7.3 Keypad

The keypad section of the control panel consists of a navigation wheel and START and STOP buttons (see Figure 7.11). The navigation wheel is used for navigating on the panel display, but it also works as a reference potentiometer when KEYPAD has been selected as the control place of the drive. The wheel has two separate functions;

- rotating the wheel e.g. for changing parameter value (12 steps / round)
- pressing the wheel e.g. for accepting the new value.

The drive stops always, regardless of the selected control place, by pressing the keypad STOP button. The drive starts by pressing the keypad START button, but only if the selected control place is KEYPAD.

**NOTE!** You can quickly change the active control place from remote (I/O or fieldbus) to local (keypad) by pressing the navigation wheel for about 5 seconds!

## 7.4 Navigation on the Vacon 10 control panel

This chapter provides you with information on navigating the menus on Vacon 10 and editing the values of the parameters.

### 7.4.1 Main menu

The menu structure of Vacon 10 control software consists of a main menu and several submenus. Navigation in the main menu is shown below:

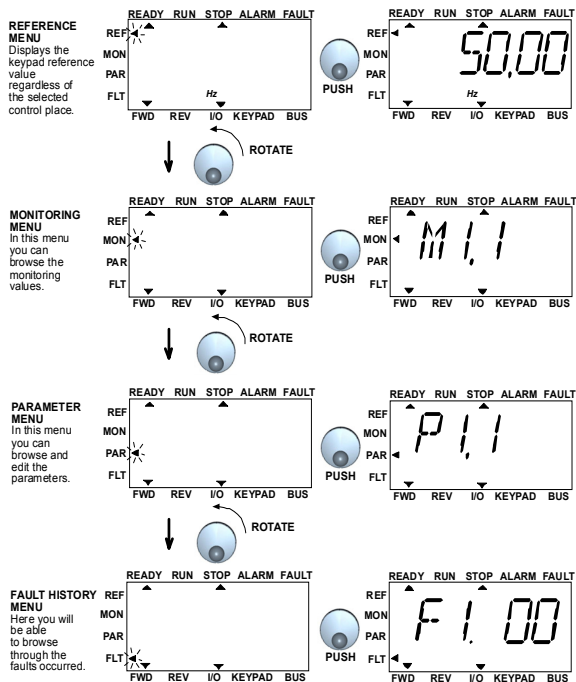

Figure 7.12: The main menu of Vacon 10

### 7.4.2 Reference menu

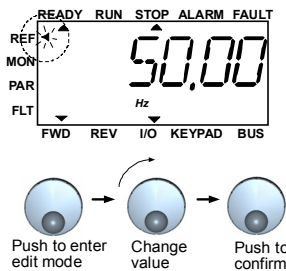

Figure 7.13: Reference menu display

Move to the reference menu with the navigation wheel (see Figure 7.12). The reference value can be changed with the navigation wheel as shown in Figure 7.13. The reference value follows the rotation continuously (= without separate new value acceptance).

## 7.4.3 Monitoring menu

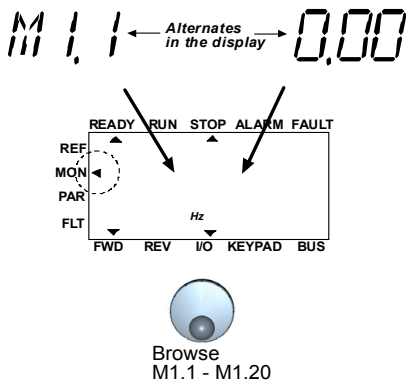

Figure 7.14: Monitoring menu display

Monitoring values mean actual values of measured signals as well as statuses of some control settings. They are visible in API Full and Limited display, but they cannot be edited. The monitoring values are listed in Table 7.15.

Pushing the navigation wheel once in this menu takes the user to the next level, where the monitoring value, e.g. M1.1 and value are visible (see Figure 7.12). The monitoring values can be browsed by rolling the navigation wheel clockwise, as shown in Figure 7.14.

Code	Monitoring signal	Unit	ID	Description
M1.1	Output frequency	Hz	1	Frequency to the motor
M1.2	Frequency reference	Hz	25	
M1.3	Motor shaft speed	rpm	2	Calculated motor speed
M1.4	Motor current	A	3	Measured motor current
M1.5	Motor torque	%	4	Calculated actual/nominal torque of the motor
M1.6	Motor power	%	5	Calculated actual/nominal power of the motor
M1.7	Motor voltage	V	6	Motor voltage
M1.8	DC-link voltage	V	7	Measured DC-link voltage
M1.9	Unit temperature	°C	8	Heat sink temperature
M1.10	Motor temperature	%		Calculated motor temperature
M1.11	Analogue input 1	%	13	AI1 value
M1.12	Analogue input 2	%	14	AI2 value <b>ONLY IN API FULL!</b>
M1.13	Analogue output	%	26	AO1 <b>ONLY IN API FULL!</b>
M1.14	DI1, DI2, DI3		15	Digital input statuses
M1.15	DI4, DI5, DI6		16	Digital input statuses <b>ONLY IN API FULL!</b>
M1.16	RO1, (also RO2, DO in API FULL)		17	Relay/digital output statuses
M1.17	PI setpoint	%	20	In percent of the maximum process reference
M1.18	PI feedback	%	21	In percent of the maximum actual value
M1.19	PI error value	%	22	In percent of the maximum error value
M1.20	PI Output	%	23	In percent of the maximum output value

Table 7.15: Vacon 10 monitoring signals

#### 7.4.4 Parameter menu

In Parameter menu only the Quick setup parameter list is shown by default. By giving the value 0 to the parameter 13.1, it is possible to open other advanced parameter groups. The parameter lists and descriptions can be found in chapters 8 and 9.

The following figure shows the parameter menu view:

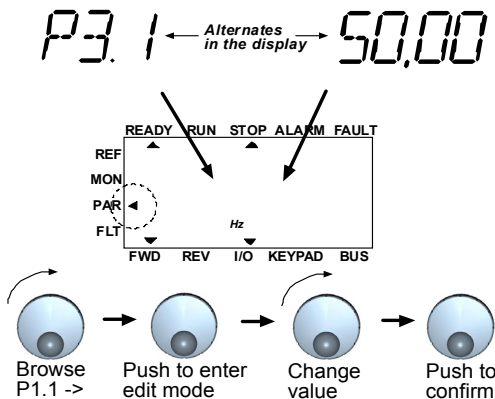

Figure 7.15: Parameter menu

## 7.4.5 Fault history menu

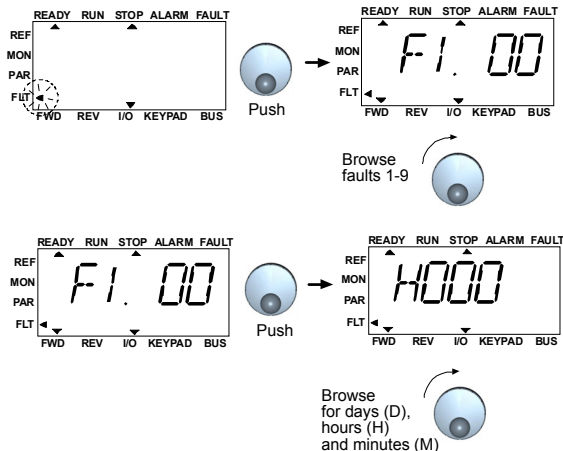

Figure 7.16: Fault history menu

In Fault history menu you can browse through 9 latest faults (see Figure 7.16). If a fault is active, the relevant fault number (e.g. F1 02) alternates in the display with main menu. When you browse between the faults, the fault codes of active faults are blinking. The active faults can be reset by pressing the STOP button for 1 time. If the fault cannot be reset, the blinking continues. It is possible to navigate in the menu structure also when there are active faults present, but the display returns automatically to the fault menu if buttons or navigation wheel are not pressed or navigation is not rotated. The operating date, hour and minute values at the fault instant are shown in the value menu (operating hours = displayed reading).

**Note! The whole fault history can be cleared by pressing STOP button for 5 sec time when the drive is stopped and Fault history menu is selected in the display.**

See Chapter 5 for fault descriptions



## 8. STANDARD APPLICATION PARAMETERS

On the next pages you can find the lists of parameters within the respective parameter groups. The parameter descriptions are given in Chapter 9.

**NOTE: Parameters can only be changed when drive is in stop mode!**

### *Explanations:*

**Code:** Location indication on the keypad; Shows the operator the present Monitoring value number or Parameter number

**Parameter:** Name of monitoring value or parameter

**Min:** Minimum value of parameter

**Max:** Maximum value of parameter

**Unit:** Unit of parameter value; given if available

**Default:** Factory preset value

**ID:** ID number of the parameter (used with fieldbus control)

 More information on this parameter available in chapter 9: 'Parameter descriptions' click on the parameter name.

**NOTE: This manual is for Vacon 10 standard application only. If you are using a special application, please download the appropriate user manual on <http://www.vacon.com> -> Support & Downloads.**

## 8.1 Quick setup parameters (Virtual menu, shows when par. 13.1 = 1)

Code	Parameter	Min	Max	Unit	Default	ID	Note
P1.1	Motor nominal voltage	180	690	V	230 400 575	110	Check rating plate on the motor
P1.2	Motor nominal frequency	30	320	Hz	50,00	111	Check rating plate on the motor
P1.3	Motor nominal speed	300	20000	rpm	1440	112	Default applies for a 4-pole motor.
P1.4	Motor nominal current	0,2 x I <sub>NUnit</sub>	2,0 x I <sub>NUnit</sub>	A	I <sub>NUnit</sub>	113	Check rating plate on the motor
P1.5	Motor cos $\phi$	0,30	1,00		0,85	120	Check rating plate on the motor
i P1.7	Current limit	0,2 x I <sub>NUnit</sub>	2 x I <sub>NUnit</sub>	A	1,5 x I <sub>NUnit</sub>	107	
i P1.15	Torque boost	0	1		0	109	0 = Not used 1 = Used
i P2.1	Remote control place	1	2		1	172	1 = I/O terminal 2 = Fieldbus (one selection removed)
i P2.2	Start function	0	1		0	505	0 = Ramp 1 = Flying start
i P2.3	Stop function	0	1		0	506	0 = Coasting 1 = Ramp
P3.1	Min frequency	0,00	P3.2	Hz	0,00	101	
P3.2	Max frequency	P3.1	320	Hz	50,00	102	
i P3.3	I/O reference	0	4		3	117	0 = Preset Speeds [0-7] 1 = Keypad Reference 2 = Fieldbus Reference 3 = AI1 (API FULL & LIMITED) 4 = AI2 (API FULL)
i P3.4	Preset speed 0	0,00	P3.2	Hz	5,00	124	Activated by digital inputs
i P3.5	Preset speed 1	0,00	P3.2	Hz	10,00	105	Activated by digital inputs
i P3.6	Preset speed 2	0,00	P3.2	Hz	15,00	106	Activated by digital inputs
i P3.7	Preset speed 3	0,00	P3.2	Hz	20,00	126	Activated by digital inputs
P4.2	Acceleration time	0,1	3000	s	1,0	103	Acceleration time from 0 Hz to maximum frequency

Table 8.1: Quick setup parameters

Code	Parameter	Min	Max	Unit	Default	ID	Note
P4.3	Deceleration time	0,1	3000	s	1,0	104	Deceleration time from maximum frequency to 0 Hz.
P6.1	AI1 Signal range	0	3		0	379	<b>API FULL and LIMITED:</b> 0 = Voltage 0...10 V 1 = Voltage 2...10 V <b>API LIMITED ONLY:</b> 2 = Current 0...20 mA 3 = Current 4...20 mA <b>NOTE:</b> When using API LIMITED, select the voltage/current range also with the dip switch
P6.5	AI2 Signal range <b>(API Full only)</b>	2	3		3	390	2 = Current 0...20 mA 3 = Current 4...20 mA
P10.4	Fault autoreset	0	1		0	731	0 = Not used 1 = Used
P13.1	Parameter conceal	0	1		1	115	0 = All parameters visible 1 = Only quick setup parameter group visible

Table 8.1: Quick setup parameters

## 8.2 Motor settings (Control panel: Menu PAR -&gt; P1)

Code	Parameter	Min	Max	Unit	Default	ID	Note
P1.1	Motor nominal voltage	180	690	V	230 400 575	110	Check rating plate on the motor
P1.2	Motor nominal frequency	30	320	Hz	50,00	111	Check rating plate on the motor
P1.3	Motor nominal speed	300	20000	rpm	1440	112	Default applies for a 4-pole motor.
P1.4	Motor nominal current	0,2 x $I_{Nunit}$	2,0 x $I_{Nunit}$	A	$I_{Nunit}$	113	Check rating plate on the motor
P1.5	Motor cos $\phi$	0,30	1,00		0,85	120	Check rating plate on the motor
① P1.7	Current limit	0,2 x $I_{Nunit}$	2 x $I_{Nunit}$	A	1,5 x $I_{Nunit}$	107	
① P1.8	Motor control mode	0	1		0	600	0 = Frequency control 1 = Speed control
① P1.9	U/f ratio selection	0	2		0	108	0 = Linear 1 = Squared 2 = Programmable
① P1.10	Field weakening point	30,00	320	Hz	50,00	602	
① P1.11	Voltage at field weakening point	10,00	200	%	100,00	603	% of Nominal voltage of the motor
① P1.12	U/f curve midpoint frequency	0,00	P1.10	Hz	50,00	604	
① P1.13	U/f curve midpoint voltage	0,00	P1.11	%	100,00	605	% of Nominal voltage of the motor
① P1.14	Output voltage at zero frequency	0,00	40,00	%	0,00	606	% of Nominal voltage of the motor
① P1.15	Torque boost	0	1		0	109	0 = Not used 1 = Used
① P1.16	Switching frequency	1,5	16,0	kHz	6,0	601	
① P1.17	Brake chopper	0	2		0	504	0=Disabled 1=Used in Run state 2=Used in Run and Stop state
<b>Only in API FULL &amp; LIMITED</b>							
① P1.18	Motor identification	0	1		0	631	1=Identification without run after start command

Table 8.2: Motor settings

**NOTE!** These parameters are shown, when P13.1 = 0.

## 8.3 Start/stop setup (Control panel: Menu PAR -&gt; P2)

	Code	Parameter	Min	Max	Unit	Default	ID	Note
i	P2.1	Remote control place	1	2		1	172	1 = I/O terminal 2 = Fieldbus (keypad control is activated with par. 2.5)
i	P2.2	Start function	0	1		0	505	0 = Ramp 1 = Flying start
i	P2.3	Stop function	0	1		0	506	0 = Coasting 1 = Ramp
i	P2.4	Start/Stop logic	0	3		0	300	<b>Start signal 1 (Default DI1)</b> 0 Start Fwd 1 Start Reverse 2 Start Pulse 3 Start Fwd REAF <b>Start signal 2 (Default DI2)</b> Start reverse Reverse Stop Pulse Start Rv REAF
i	P2.5	Local/remote	0	1			211	0 = Remote 1 = Keypad

Table 8.3: Start/stop setup

## 8.4 Frequency references (Control panel: Menu PAR -&gt; P3)

	Code	Parameter	Min	Max	Unit	Default	ID	Note
	P3.1	Min frequency	0,00	P3.2	Hz	0,00	101	
	P3.2	Max frequency	P3.1	320	Hz	50,00	102	
i	P3.3	I/O reference	0	4		3	117	0 = Preset Speeds (0-7) 1 = Keypad Reference 2 = Fieldbus Reference 3 = AI1 (API FULL & LIMITED) 4 = AI2 (API FULL)
i	P3.4	Preset speed 0	0,00	P3.2	Hz	5,00	124	Activated by digital inputs
i	P3.5	Preset speed 1	0,00	P3.2	Hz	10,00	105	Activated by digital inputs
i	P3.6	Preset speed 2	0,00	P3.2	Hz	15,00	106	Activated by digital inputs
i	P3.7	Preset speed 3	0,00	P3.2	Hz	20,00	126	Activated by digital inputs
i	P3.8	Preset speed 4	0,00	P3.2	Hz	25,00	127	Activated by digital inputs
i	P3.9	Preset speed 5	0,00	P3.2	Hz	30,00	128	Activated by digital inputs
i	P3.10	Preset speed 6	0,00	P3.2	Hz	40,00	129	Activated by digital inputs
i	P3.11	Preset speed 7	0,00	P3.2	Hz	50,00	130	Activated by digital inputs

Table 8.4: Frequency references

**NOTE!** These parameters are shown, when P13.1 = 0.

## 8.5 Ramps and brakes setup (Control panel: Menu PAR -&gt; P4)

Code	Parameter	Min	Max	Unit	Default	ID	Note
i P4.1	Ramp shape	0,0	10,0	s	0,0	500	0 = Linear >0 = S-curve ramp time
i P4.2	Acceleration time	0,1	3000	s	1,0	103	
i P4.3	Deceleration time	0,1	3000	s	1,0	104	
P4.4	DC braking current	0.2 x I <sub>Nunit</sub>	2 x I <sub>Nunit</sub>	A	Varies	507	
i P4.5	DC braking time at start	0,00	600.00	s	0	516	0 = DC brake is off at start
i P4.6	Frequency to start DC braking during ramp stop	0,10	10,00	Hz	1,50	515	
i P4.7	DC braking time at stop	0,00	600.00	s	0	508	0 = DC brake is off at stop
i P4.8	Flux brake	0	3			520	0 = Off 2 = Chopper 1 = On 3 = Full mode
P4.9	Flux braking current	0	7,4	A		519	
i P4.10	Ramp shape 2	0,0	10,0	s	0,0	501	0 = Linear >0 = S-curve ramp time
P4.11	Acceleration time 2	0,1	3000	s	1,0	502	
P4.12	Deceleration time 2	0,1	3000	s	1,0	503	

Table 8.5: Motor control parameters

## 8.6 Digital inputs (Control panel: Menu PAR -&gt; P5)

Code	Parameter	Min	Max	Unit	Default	ID	Note
i P5.1	Start signal 1	0	6		1	403	0 = Not used 1 = DI1 2 = DI2 <b>Only in API FULL &amp; LIMITED</b> 3 = DI3 4 = DI4 <b>Only in API FULL</b> 5 = DI5 6 = DI6
P5.2	Start signal 2	0	6		2	404	As parameter 5.1
P5.3	Reverse	0	6		0	412	As parameter 5.1
P5.4	Ext. fault Close	0	6		0	405	As parameter 5.1

Table 8.6: Digital inputs

Code	Parameter	Min	Max	Unit	Default	ID	Note
P5.5	Ext. fault Open	0	6		0	406	As parameter 5.1
P5.6	Fault reset	0	6		5	414	As parameter 5.1
P5.7	Run enable	0	6		0	407	As parameter 5.1
P5.8	Preset speed B0	0	6		3	419	As parameter 5.1
P5.9	Preset speed B1	0	6		4	420	As parameter 5.1
P5.10	Preset speed B2	0	6		0	421	As parameter 5.1
P5.11	Disable PI	0	6		6	1020	As parameter 5.1
i P5.12	Force to I/O	0	1 (FULL & LIMITED 6 (RS485)		0	409	As parameter 5.1
i P5.13	Ramp time select	0	6		0	408	As parameter 5.1

Table 8.6: Digital inputs

### 8.7 Analogue inputs (Control panel: Menu PAR -> P6)

Code	Parameter	Min	Max	Unit	Default	ID	Note
<b>Only in API FULL &amp; LIMITED</b>							
P6.1	AI1 Signal range	0	3		0	379	<b>API FULL and LIMITED:</b> 0 = Voltage 0...10 V 1 = Voltage 2...10 V <b>API LIMITED ONLY:</b> 2 = Current 0...20 mA 3 = Current 4...20 mA <b>NOTE:</b> When using API LIMITED, select the voltage/current range also with the dip switch
i P6.2	AI1 filter time	0,0	10,0	s	0,1	378	0 = no filtering
i P6.3	AI1 Custom min	-100,0	100,0	%	0,0	380	0,0 = no min scaling
i P6.4	AI1 Custom max	-100,0	100,0	%	100,0	381	100,0 = no max scaling
<b>Only in API FULL</b>							
P6.5	AI2 signal range	2	3		3	390	2 = Current 0...20 mA 3 = Current 4...20 mA
i P6.6	AI2 filter time	0,0	10,0	s	0,1	389	0 = no filtering
i P6.7	AI2 Custom min	-100,0	100,0	%	0,0	391	0,0 = no min scaling
i P6.8	AI2 Custom max	-100,0	100,0	%	100,0	392	100,0 = no max scaling

Table 8.7: Analogue inputs

## 8.8 Digital and analogue outputs (Control panel: Menu PAR -&gt; P7)

Code	Parameter	Min	Max	Unit	Default	ID	Selections
<b>Only in API FULL</b>							
i P7.1	Relay output 1 content	0	11		2	313	0 = Not used 1 = Ready 2 = Run 3 = Fault 4 = Fault Inverted 5 = Alarm 6 = Reversed 7 = At Speed 8 = Motor Regulator Active 9 = FBControlWord.B13 10 = FBControlWord.B14 11 = FBControlWord.B15
<b>In all API versions</b>							
P7.2	Relay output 2 content	0	11		3	314	As parameter 7.1
<b>Only in API FULL</b>							
P7.3	Digital output 1 content	0	11		1	312	As parameter 7.1
i P7.4	Analogue output function	0	4		1	307	0 = Not in use 1 = Output freq. (0-f <sub>max</sub> ) 2 = Output current (0-I <sub>nMotor</sub> ) 3 = Torque (0-Nominal torque) 4 = PI controller output
i P7.5	Analogue output minimum	0	1		1	310	0 = 0 mA 1 = 4 mA
<b>Only in API Limited</b>							
P7.6	Relay 2 invert	0	1		0	489	1 = Relay 2 inverted

Table 8.8: Digital and analogue outputs



## 8.9 Protections (Control panel: Menu PAR -&gt; P9)

Code	Parameter	Min	Max	Unit	Default	ID	Note
P9.1	Response to 4mA reference fault	1	2		1	700	0 = No response 1 = Alarm 2 = Fault, stop acc. to P2.3
P9.2	Response to undervoltage fault	1	2		2	727	1 = Alarm 2 = Fault, stop acc. to P2.3
P9.3	Earth fault protection	1	2		2	703	1 = Alarm 2 = Fault, stop acc. to P2.3
i P9.4	Stall protection	1	2		1	709	0 = No response 1 = Alarm 2 = Fault, stop acc. to P2.3
i P9.5	Underload protection	1	2		1	713	0 = No response 1 = Alarm 2 = Fault, stop acc. to P2.3
i P9.7	Thermal protection of the motor	1	2		2	704	0 = No response 1 = Alarm 2 = Fault, stop acc. to P2.3
i P9.8	Motor ambient temperature	-20	100	°C	40	705	
i P9.9	Motor cooling factor at zero speed	0,0	150,0	%	40,0	706	
i P9.10	Motor thermal time constant	1	200	min	45	707	
P9.11	Motor Phase Supervision	0	2	unit	2	702	Description

Table 8.9: Protections

**NOTE!** These parameters are shown, when P13.1 = 0.

## 8.10 Fault autoreset parameters (Control panel: Menu PAR -&gt; P10)

Code	Parameter	Min	Max	Unit	Default	ID	Note
P10.1	Wait time	0,10	10,00	s	0,50	717	Delay before automatic restart after a fault has disappeared
<span style="border: 1px solid black; border-radius: 50%; padding: 2px;">i</span> P10.2	Trial time	0,00	90,00 (FULL & LIMITED) 60,00 (RS485)	s	30,00	718	Defines the time before the frequency converter tries to automatically restart the motor after the fault has disappeared
P10.3	Start function	0	2		0	719	0 = Ramp 1 = Flying start 2 = According to P4.2 <b>Affects only to start after autoreset!</b>
P10.4	Fault autoreset	0	1		0	731	0 = Disabled 1 = Enabled

Table 8.10: Fault autoreset parameters

**NOTE!** These parameters are shown, when **P13.1 = 0**.

## 8.11 PI control parameters (Control panel: Menu PAR -&gt; P12)

Code	Parameter	Min	Max	Unit	Default	ID	Note
i P12.1	PI activation	0	2		0	163	0 = Not used 1 = PI for motor control 2 = PI for external use (Only in API FULL)
i P12.2	PI controller gain	0,0	1000	%	100,0	118	
i P12.3	PI controller I-time	0,00	320,0	s	10,00	119	
P12.4	Keypad PI reference	0,0	100,0	%	0,0	167	
P12.5	Setpoint source	0	3		0	332	0 = Keypad PI reference, P12.4 1 = Fieldbus 2 = AI1 Only in API FULL & LIMITED 3 = AI2 Only in API FULL
P12.6	Feedback source	0	2		2	334	0 = Fieldbus 1 = AI1 Only in API FULL & LIMITED 2 = AI2 Only in API FULL
i P12.7	Feedback minimum	0,0	100,0	%	0,0	336	0 = No minimum scaling
i P12.8	Feedback maximum	0,0	100,0	%	100,0	337	100,0 = No maximum scaling
P12.9	Error value inversion	0	1		0	340	0 = No inversion (Feedback < Setpoint -> Increase PI Output) 1 = Inverted (Feedback < Setpoint -> Decrease PI Output)

Table 8.11: PI control parameters

**NOTE!** These parameters are shown, when P13.1 = 0.

## 8.12 Easy usage menu (Control panel: Menu PAR -&gt; P0)

Code	Parameter	Min	Max	Unit	Default	ID	Note
P13.1	Parameter conceal	0	1		1	115	0 = All parameters visible 1 = Only quick setup parameter group visible
P13.2	Drive setup	0	3		0	540	0 = Basic 1 = Pump drive 2 = Fan drive 3 = Conveyor drive (HP) <b>NOTE!</b> Visible only during Startup wizard

Table 8.12: Easy usage menu parameters

## 8.13 System parameters

Code	Parameter	Min	Max	Default	ID	Note
<b>Software information (MENU PAR -&gt; S1)</b>						
S1.1	API system SW				2314	
S1.2	API system SW version				835	
S1.3	Power SW ID				2315	
S1.4	Power SW version				834	
S1.5	Application SW ID				837	
S1.6	Application SW revision				838	
S1.7	System load				839	
<b>RS485 information (MENU PAR -&gt; S2)</b>						
S2.1	Communication status				808	Format: <b>xx.yyy</b> <b>xx</b> = 0 - 64 (Number of error messages) <b>yyy</b> = 0 - 999 (Number of correct messages)
S2.2	Fieldbus protocol	0	1	0	809	0 = FB disabled 1 = Modbus
S2.3	Slave address	1	255	1	810	
S2.4	Baud rate	0	5	5	811	0=300, 1=600, 2=1200, 3=2400, 4=4800, 5=9600,
S2.5	Number of stop bits	0	1	1	812	0=1, 1=2
S2.6	Parity type	0	0	0	813	0= None (locked)
S2.7	Communication time-out	0	255	0	814	0= Not used, 1= 1 second, 2= 2 seconds, etc.

Table 8.13: System parameters

Code	Parameter	Min	Max	Default	ID	Note
S2.8	Reset communication status	0	1	0	815	1= Resets par. S2.1
<b>Total counters (MENU PAR -&gt; S3)</b>						
S3.1	MWh counter				827	
S3.2	Power on days				828	
S3.3	Power on hours				829	
<b>User settings (MENU PAR -&gt; S4)</b>						
S4.1	Display contrast	0	15	15	830	Adjusts the display contrast
S4.2	Default page	0	20	0	2318	Defines which monitoring page (1.1. - 1.20) is shown after startup. 0 = Not used
S4.3	Restore factory defaults	0	1	0	831	1= Restores factory defaults for all parameters

Table 8.13: System parameters

## 9. PARAMETER DESCRIPTIONS

On the next pages you can find the descriptions of certain parameters. The descriptions have been arranged according to parameter group and number.

### 9.1 Motor settings (Control panel: Menu PAR -> P1)

#### 1.7 CURRENT LIMIT

This parameter determines the maximum motor current from the frequency converter. To avoid motor overload, set this parameter according to the rated current of the motor. The current limit is equal to the rated converter current ( $I_n$ ) by default.

#### 1.8 MOTOR CONTROL MODE

With this parameter the user can select the motor control mode. The selections are:

**0 = Frequency control:**

Drive frequency reference is set to output frequency without slip compensation. Motor actual speed is finally defined by motor load.

**1 = Speed control:**

Drive frequency reference is set to motor speed reference. The motor speed remains the same regardless of motor load. Slip is compensated.

#### 1.9 U/F RATIO SELECTION

There are three selections for this parameter:

**0 = Linear:**

The voltage of the motor changes linearly with the frequency in the constant flux area from 0 Hz to the field weakening point where the field weakening point voltage is supplied to the motor. Linear U/f ratio should be used in constant torque applications. See Figure 9.1.

This default setting should be used if there is no special need for another setting.

**1 = Squared:**

The voltage of the motor changes following a squared curve form with the frequency in the area from 0 Hz to the field weakening point where the field weakening point voltage is also supplied to the motor. The motor runs under magnetised below the field weakening point and produces less torque, power losses and electromechanical noise. Squared U/f ratio can be used in applications where torque demand of the load is proportional to the square of the speed, e.g in centrifugal fans and pumps

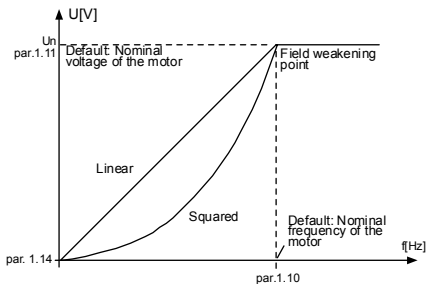

Figure 9.1: Linear and squared change of motor voltage

**2 = Programmable U/f curve:**

The U/f curve can be programmed with three different points. Programmable U/f curve can be used if the other settings do not satisfy the needs of the application

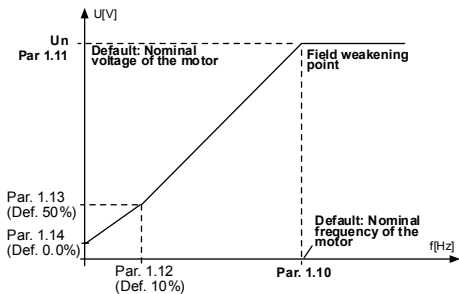

Figure 9.2: Programmable U/f curve



### **1.10 FIELD WEAKENING POINT**

The field weakening point is the output frequency at which the output voltage reaches the value set with par. 1.11.

### **1.11 VOLTAGE AT FIELD WEAKENING POINT**

Above the frequency at the field weakening point, the output voltage remains at the value set with this parameter. Below the frequency at the field weakening point, the output voltage depends on the setting of the U/f curve parameters. See parameters 1.9 - 1.14 and Figures 9.1 and 9.2.

When the parameters 1.1 and 1.2 (nominal voltage and nominal frequency of the motor) are set, the parameters 1.10 and 1.11 are automatically given the corresponding values. If you need different values for the field weakening point and the voltage, change these parameters after setting the parameters 1.1 and 1.2.

### **1.12 U/F CURVE, MIDDLE POINT FREQUENCY**

If the programmable U/f curve has been selected with the parameter 1.9, this parameter defines the middle point frequency of the curve. See Figure 9.2.

### **1.13 U/F CURVE, MIDDLE POINT VOLTAGE**

If the programmable U/f curve has been selected with the parameter 1.9, this parameter defines the middle point voltage of the curve. See Figure 9.2.

### **1.14 OUTPUT VOLTAGE AT ZERO FREQUENCY**

This parameter defines the zero frequency voltage of the curve. See Figures 9.1 and 9.2.

### **1.15 TORQUE BOOST**

When this parameter has been activated, the voltage to the motor changes automatically with high load torque which makes the motor produce sufficient torque to start and run at low frequencies. The voltage increase depends on the motor type and power. Automatic torque boost can be used in applications with high load torque, e.g. in conveyors.

**0** = Disabled

**1** = Enabled

**Note:** In high torque - low speed applications - it is likely that the motor will overheat. If the motor has to run a prolonged time under these conditions, special attention must be paid to cooling the motor. Use external cooling for the motor if the temperature tends to rise too high.

**Note:** The best performance can be reached by running motor identification, see par. 1.18.

### 1.16 SWITCHING FREQUENCY

Motor noise can be minimised using a high switching frequency. Increasing the switching frequency reduces the capacity of the frequency converter unit.

Switching frequency for Vacon 10: 1.5...16 kHz.

### 1.17 BRAKE CHOPPER

**Note!** An internal brake chopper is installed in three phase supply MI2 and MI3 size drives

**0** = No brake chopper used

**1** = Brake chopper used in Run state

**2** = Used in Run and Stop state

When the frequency converter is decelerating the motor, the energy stored to the inertia of the motor and the load are fed into an external brake resistor, if the brake chopper has been activated. This enables the frequency converter to decelerate the load with a torque equal to that of acceleration (provided that the correct brake resistor has been selected). See separate Brake resistor installation manual.

### 1.18 MOTOR IDENTIFICATION

**0** = No action

**1** = ID no run

When ID no run is selected, the drive will perform an ID-run when it is started from selected control place. Drive has to be started within 20 seconds, otherwise identification is aborted.

The drive does not rotate the motor during ID no run. When ID run is ready the drive is stopped. Drive will start normally, when the next start command is given.

The ID run improves the torque calculations and the automatic torque boost function. It will also result in a better slip compensation in speed control (more accurate RPM).

## 9.2 Start/Stop setup (Control panel: Menu PAR -> P2)

### 2.1 REMOTE CONTROL PLACE

With this parameter, the user can select the active control place. The selections are:

- 1 = I/O terminal (frequency reference can be selected with P3.3)
- 2 = Fieldbus

The priority order of selecting the control place is

1. Navigation wheel
2. Forced from I/O terminal
3. Par. 2.1

**Note:** Local/Remote control mode can be toggled by pressing the navigation wheel for 5 seconds. P2.1 will have no effect in local mode.

**Local** = Keypad is the control place

**Remote** = P2.1 defines the control place

### 2.2 START FUNCTION

The user can select two start functions for Vacon 10 with this parameter:

#### 0 = Ramp start

The frequency converter starts from 0 Hz and accelerates to the set frequency reference within the set acceleration time (See detailed description: ID103). (Load inertia, torque or starting friction may cause prolonged acceleration times).

#### 1 = Flying start

With this function the drive identifies the speed of the motor and starts to the corresponding frequency immediately.

Use this mode if the motor is rotating when the start command is given. With the flying start, it is possible to ride through short mains voltage interruptions

### 2.3 STOP FUNCTION

Two stop functions can be selected in this application:

#### 0 = Coasting

The motor coasts to a halt without control from the frequency converter after the Stop command.

#### 1 = Ramp stop

After the Stop command, the speed of the motor is decelerated according to the set deceleration parameters.

If the regenerated energy is high it may be necessary to use an external braking resistor for to be able to decelerate the motor in acceptable time.

### 2.4 START/STOP LOGIC

With this parameter the user can select the start/stop logic.

0 = DI 1 = Start forward

DI 2 = Start reverse (API FULL & LIMITED)

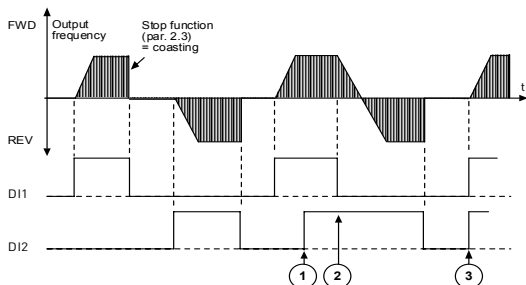

Figure 9.3: Start/Stop logic, selection 0

- ① The first selected direction has the highest priority.
- ② When the DIN1 contact opens the direction of rotation starts the change.
- ③ If Start forward (DI1) and Start reverse (DI2) signals are active simultaneously the Start forward signal (DI1) has priority

- 1 = DI1 = Start  
DI2 = Reverse (API FULL & LIMITED)

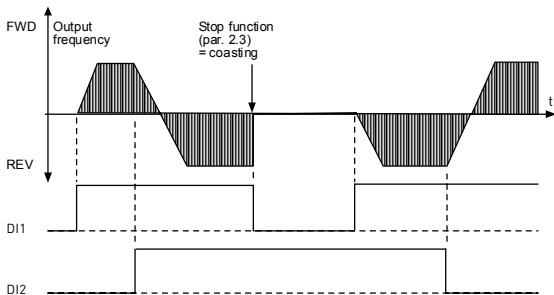

Figure 9.4: Start/Stop logic, selection 1

- 2 = DI1 = Start pulse  
DI2 = Stop pulse (API FULL & LIMITED)

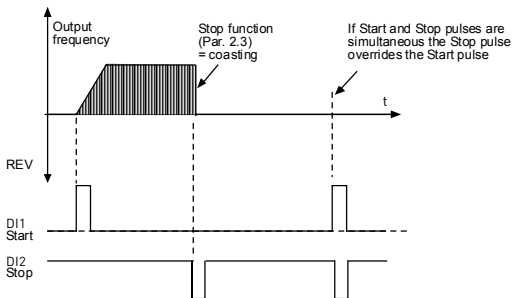

Figure 9.5: Start/Stop logic, selection 2

- 3 = DI1 = Start forward, rising edge after fault  
DI2 = Start reverse, rising edge after fault (API FULL & LIMITED)

## 2.5 LOCAL/REMOTE

This parameter defines whether the control place of the drive is remote (I/O or FieldBus) or Keypad. Keypad can also be selected as control place by pressing the navigation wheel for 5 seconds.

The priority order of selecting control place is

1. Navigation wheel
2. Forced from I/O
3. Parameter 2.1

### 9.3 Frequency references (Control panel: Menu PAR -> P3)

#### 3.3 I/O REFERENCE

Defines the selected frequency reference source when the drive is controlled from the I/O terminal.

**0** = Preset speed 0 - 7

**1** = Keypad reference

**2** = Reference from Fieldbus (FBSpeedReference)

**API FULL & LIMITED:**

**3** = AI1 reference (terminals 2 and 3, e.g. potentiometer)

**API FULL:**

**4** = AI2 reference (terminal 4 and 5, e.g. transducer)

#### 3.4 - 3.11 PRESET SPEEDS 0 - 7

These parameters can be used to determine frequency references that are applied when appropriate combinations of digital inputs are activated. Preset speeds can be activated from digital inputs despite of the active control place.

Parameter values are automatically limited between the minimum and maximum frequencies. (par. 3.1, 3.2).

Speed	Preset speed B2	Preset speed B1	Preset speed B0
If P3.3 = 0, Preset speed 0			
Preset speed 1			x
Preset speed 2		x	
Preset speed 3		x	x
Preset speed 4	x		
Preset speed 5	x		x
Preset speed 6	x	x	
Preset speed 7	x	x	x

Table 9.1: Preset speeds 0 - 7

## 9.4 Ramps & brakes setup (Control panel: Menu PAR -> P4)

### 4.1 RAMP SHAPE

#### 4.10 RAMP SHAPE 2

The start and end of the acceleration and deceleration ramp can be smoothed with this parameter. Setting value 0 gives a linear ramp shape which causes acceleration and deceleration to act immediately to the changes in the reference signal.

Setting value 0.1...10 seconds for this parameter produces an S-shaped acceleration/deceleration. The acceleration and deceleration times are determined with parameters 4.2 and 4.3.

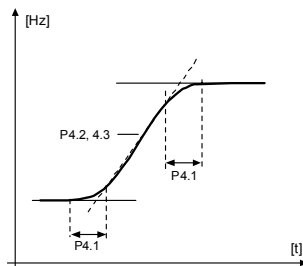

Figure 9.6: S-shaped acceleration/deceleration

### 4.2 ACCELERATION TIME

### 4.3 DECELERATION TIME

#### 4.11 ACCELERATION TIME 2

#### 4.12 DECELERATION TIME 2

These limits correspond to the time required for the output frequency to accelerate from the zero frequency to the set maximum frequency, or to decelerate from the set maximum frequency to zero frequency.

The user can set two different acceleration/deceleration time sets for one application. The active set can be selected with the selected digital input (par. 5.13)



#### 4.5 DC BRAKING TIME AT START

DC-brake is activated when the start command is given. This parameter defines the time of the DC-braking. After the brake is released, the output frequency increases according to the set start function by par. 2.2.

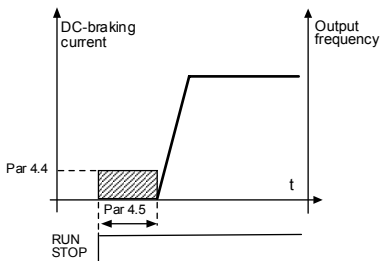

Figure 9.7: DC braking time at start

#### 4.6 FREQUENCY TO START DC BRAKING DURING RAMP STOP

The output frequency at which the DC-braking is applied. See Figure 9.9.

#### 4.7 DC BRAKING TIME AT STOP

Determines if braking is ON or OFF and the braking time of the DC-brake when the motor is stopping. The function of the DC-brake depends on the stop function, par. 2.3.

**0** = DC brake is not in use

**>0** = DC brake is in use and its function depends on the Stop function, (par. 2.3). The DC braking time is determined with this parameter.

#### Par. 2.3 = 0 (Stop function = Coasting):

After the stop command, the motor coasts to a stop without control from the frequency converter.

With the DC injection, the motor can be electrically stopped in the shortest possible time, without using an optional external braking resistor.

The braking time is scaled by the frequency when the DC-braking starts. If the frequency is greater, or equal to the nominal frequency of the motor, the set value of parameter 4.7 determines the braking time. For example, when the frequency is 10% of the nominal, the braking time is 10% of the set value of parameter 4.7.

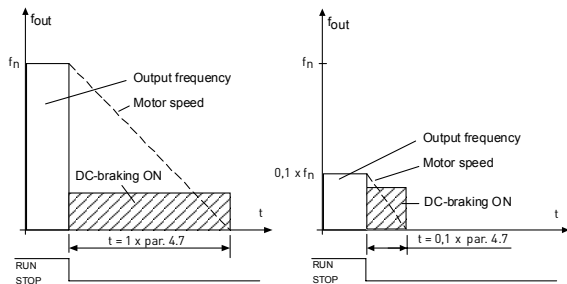

Figure 9.8: DC-braking time when Stop mode = Coasting

**Par. 2.3 = 1 (Stop function = Ramp):**

After the Stop command, the speed of the motor is reduced according to the set deceleration parameters, if the inertia of the motor and load allows that, to the speed defined with parameter 4.6, where the DC-braking starts.

The braking time is defined with parameter 4.7. See Figure 9.9.

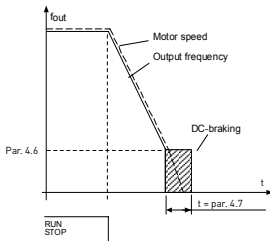

Figure 9.9: DC-braking time when Stop mode = Ramp

**4.8 FLUX BRAKE**

Instead of DC braking, flux braking is a useful form of braking with motors of max. 15kW.

When braking is needed, the frequency is reduced and the flux in the motor is increased, which in turn increases the motor's capability to brake. Unlike DC braking, the motor speed remains controlled during braking.

Activation mode	Description
0 = Off	Not used
1 = On	Normal mode. Activates flux braking during deceleration regardless of load.
2 = Chopper	Emulates the behavior of a braking chopper by activating flux braking based on DC-link voltage. Minimizes the heating up of the motor in applications with frequent speed changes.
3 = Full mode	Activates flux braking both during deceleration and on generative shock loads at constant speed. Offers the highest performance in demanding applications.

**Note:** Flux braking converts the energy into heat at the motor, and should be used intermittently to avoid motor damage.

## 9.5 Digital inputs (Control panel: Menu PAR -> P5)

These parameters are programmed using the FTT-method (Function To Terminal), where you have a fixed input or output that you define a certain function for. You can also define more than one function to a digital input, e.g. Start signal 1 and Preset Speed B1 to DI1.

The selections for these parameters are:

- 0 = Not used
- 1 = DI1
- 2 = DI2 (API FULL & LIMITED)
- 3 = DI3 (API FULL & LIMITED)
- 4 = DI4 (API FULL)
- 5 = DI5 (API FULL)
- 6 = DI6 (API FULL)

- 5.1 START SIGNAL 1**
- 5.2 START SIGNAL 2**
- 5.3 REVERSE**
- 5.4 EXTERNAL FAULT (CLOSE)**
- 5.5 EXTERNAL FAULT (OPEN)**
- 5.6 FAULT RESET**
- 5.7 RUN ENABLE**
- 5.8 PRESET SPEED B0**
- 5.9 PRESET SPEED B1**
- 5.10 PRESET SPEED B2**
- 5.11 DISABLE PI**
- 5.12 FORCE TO I/O**

The control place is forced to I/O by activating the digital input that this function is programmed to.

The priority order of selecting control place is

1. Navigation wheel
2. Forced from I/O
3. Parameter 2.1

### 5.13 RAMP TIME SELECTION

Contact open: Acceleration/Deceleration time 1 selected

Contact closed: Acceleration/Deceleration time 2 selected

Set Acceleration/Deceleration times with parameters 4.2 and 4.3 and the alternative ramp times with 4.11 and 4.12.

## 9.6 Analogue inputs (Control panel: Menu PAR -> P6)

### 6.2 AI1 SIGNAL FILTER TIME (ONLY IN API FULL & LIMITED)

### 6.6 AI2 SIGNAL FILTER TIME (ONLY IN API FULL)

This parameter, given a value greater than 0, activates the function that filters out disturbances from the incoming analogue signal.

Long filtering time makes the regulation response slower. See Figure 9.10.

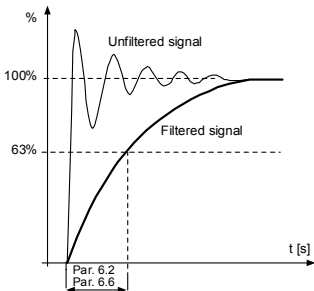

Figure 9.10: AI1 and AI2 signal filtering

### 6.3 AI1 CUSTOM SETTING MINIMUM

### 6.4 AI1 CUSTOM SETTING MAXIMUM

### 6.7 AI2 CUSTOM SETTING MINIMUM

### 6.8 AI2 CUSTOM SETTING MAXIMUM

These parameters set the analogue input signal for any input signal span from -100 to 100%.

## 9.7 Digital and analogue outputs (Control panel: Menu PAR -> P7)

### 7.1 RELAY OUTPUT 1 FUNCTION (ONLY IN API FULL)

### 7.2 RELAY OUTPUT 2 FUNCTION

### 7.3 DIGITAL OUTPUT 1 FUNCTION (ONLY IN API FULL)

Setting	Signal content
0 = Not used	Not in operation
1 = Ready	The frequency converter is ready to operate
2 = Run	The frequency converter operates (motor is running, or DC-braking)
3 = Fault	A fault trip has occurred
4 = Fault inverted	A fault trip has not occurred
5 = Alarm	An alarm has occurred
6 = Reversed	The reverse command has been selected, output frequency to the motor is negative.
7 = At speed	The output frequency has reached the set reference
8 = Motor regulator activated	One of the limit regulators (e.g. current limit, voltage limit) is activated
9 = FBControlWord.B13	Modbus control word bit 13
10 = FBControlWord.B14	Modbus control word bit 14
11 = FBControlWord.B15	Modbus control word bit 15

Table 9.2: Output signals via RO1, RO2 and DO1

### 7.4 ANALOGUE OUTPUT FUNCTION

- 0 = Full scale
- 1 = 0 - Max. frequency
- 2 = 0 - Nominal current
- 3 = 0 - Nominal torque
- 4 = PID controller output, 0-100%

### 7.5 ANALOGUE OUTPUT MINIMUM

- 0 = 0-20 mA, 0-10V
- 1 = 4-20 mA, 2-10V

## 9.8 Motor thermal protection (parameters 9.7 - 9.10)

The motor thermal protection is to protect the motor from overheating. The drive is capable of supplying higher than nominal current to the motor. If the load requires this high current there is a risk that the motor will be thermally overloaded. This is the case especially at low frequencies. At low frequencies the cooling effect of the motor is reduced as well as its capacity. If the motor is equipped with an external fan the load reduction at low speeds is small.

The motor thermal protection is based on a calculated model and it uses the output current of the drive to determine the load on the motor.

The motor thermal protection can be adjusted with parameters. The thermal current  $I_T$  specifies the load current above which the motor is overloaded. This current limit is a function of the output frequency.

**CAUTION! The calculated model does not protect the motor if the airflow to the motor is reduced by blocked air intake grill**

## 9.4 STALL PROTECTION

0 = No response

1 = Alarm

2 = Fault, stop according to P2.3

The motor stall protection protects the motor from short time overload situations such as one caused by a stalled shaft. The stall current is  $I_{nMotor} * 1.3$ , stall time 15 seconds and stall frequency limit 25Hz. If the current is higher than the limit and output frequency is lower than the limit, the stall state is true and the drive reacts according to this parameter. There is actually no real indication of the shaft rotation.

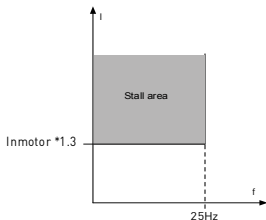

Figure 9.11: Stall characteristics

### 9.5 UNDERLOAD PROTECTION

0 = No response

1 = Alarm

2 = Fault, stop according to P2.3

The purpose of the motor underload protection is to ensure that there is load on the motor when the drive is running. If the motor loses its load there might be a problem in the process, e.g. a broken belt or a dry pump.

The underload protection time limit is 20 seconds, which is the maximum time allowed for an underload state to exist before causing a trip according to this parameter.

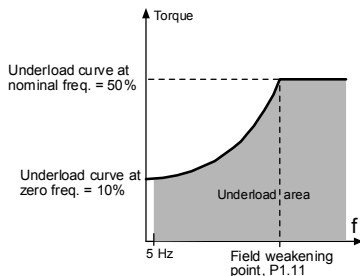

Figure 9.12: Underload protection



### **9.7 THERMAL PROTECTION OF THE MOTOR**

**0** = No response

**1** = Alarm

**2** = Fault, stop mode after fault according to parameter

If tripping is selected the drive will stop and activate the fault stage, if the temperature of the motor becomes too high. Deactivating the protection, i.e. setting parameter to 0, will reset the thermal model of the motor to 0%.

### **9.8 MOTOR AMBIENT TEMPERATURE**

When the motor ambient temperature must be taken into consideration, it is recommended to set a value for this parameter. The value can be set between -20 and 100 degrees Celsius.

### 9.9 MOTOR COOLING FACTOR AT ZERO SPEED

The cooling power can be set between 0-150.0% x cooling power at nominal frequency. See Figure 9.13.

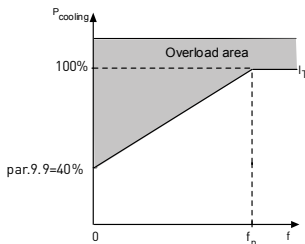

Figure 9.13: Motor cooling power

### 9.10 MOTOR THERMAL TIME CONSTANT

This time can be set between 1 and 200 minutes.

This is the thermal time constant of the motor. The bigger the motor, the bigger the time constant. The time constant is the time within which the calculated thermal model has reached 63% of its final value.

The motor thermal time is specific to the motor design and it varies between different motor manufacturers.

If the motor's  $t_6$ -time ( $t_6$  is the time in seconds the motor can safely operate at six times the rated current) is known (given by the motor manufacturer) the time constant parameter can be set basing on it. As a rule of thumb, the motor thermal time constant in minutes equals to  $2 \times t_6$ . If the drive is in stop state the time constant is internally increased to three times the set parameter value. See also Figure 9.9.

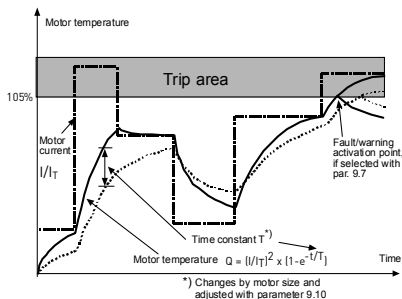

Figure 9.14: Motor temperature calculation

### 9.11 MOTOR PHASE SUPERVISION

Motor phase supervision of the motor ensures that the motor phases have an approximately equal current.

Settings for P9.11, range 0-2:

Activation mode	Description
0	No response
1	Warning
2	Fault, stop mode after fault according to ID506 (P2.3 Stop function)

## 9.9 Fault autoreset parameters (Control panel: Menu PAR -> P10)

### 10.2 AUTO RESET, TRIAL TIME

The Automatic restart function restarts the frequency converter when the faults have disappeared and the waiting time has elapsed.

The time count starts from the first autoreset. If the number of faults occurring during the trial time exceeds three, the fault state becomes active. Otherwise the fault is cleared after the trial time has elapsed and the next fault starts the trial time count again. See Figure 9.15.

If a single fault remains during the trial time, a fault state is true.

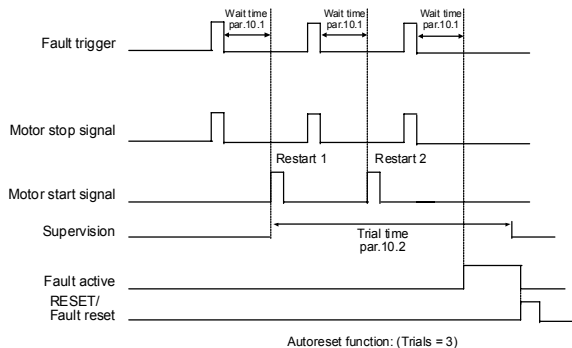

Figure 9.15: Automatic restart

## 9.10 PI control parameters (Control panel: Menu PAR -> P12)

### 12.1 PI ACTIVATION

- 0 = Not used
- 1 = PI for motor control
- 2 = PI for external use (Only in API Full!)

### 12.2 PI CONTROLLER GAIN

This parameter defines the gain of the PI controller. If the value of the parameter is set to 100% a change of 10% in the error value causes the controller output to change by 10%.

### 12.3 PI CONTROLLER I-TIME

This parameter defines the integration time of the PI controller. If this parameter is set to 1,00 second the controller output is changed by a value corresponding to the output caused from the gain every second. (Gain\*Error)/s.

### 12.7 FEEDBACK MINIMUM

### 12.8 FEEDBACK MAXIMUM

This parameter sets the minimum and maximum scaling points for feedback value.

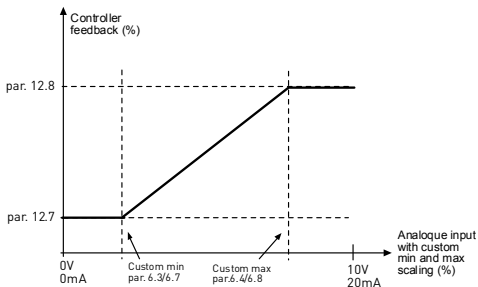

Figure 9.16: Feedback minimum and maximum

## 9.11 Easy usage menu (Control panel: Menu PAR -&gt; P9)

## 13.2 DRIVE SETUP

With this parameter you can easily set up your drive for four different applications.

**Note!** This parameter is only visible when the Startup Wizard is active. The startup wizard will start in first power-up. It can also be started as follows. See the figures below.

**NOTE!** Running the startup wizard will always return all parameter settings to their factory defaults!

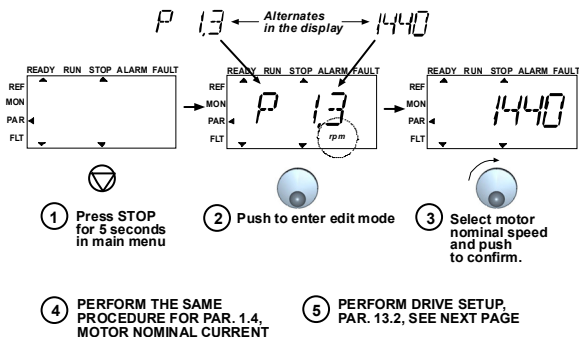
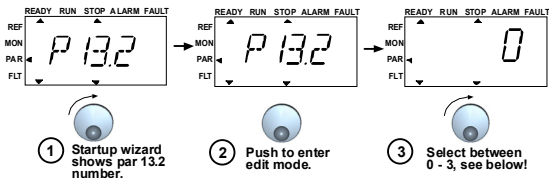

Figure 9.17: Startup wizard



## Selections:

	P1.1	P1.2	P1.7	P1.15	P2.1	P2.2	P2.3	P3.1	P3.2	P3.3	P4.2	P4.3
0 = Basic	V*	50/60 Hz	1,1 x I <sub>NMOT</sub>	0= Not used	I/O	0= Ramp	0= Coast.	0 Hz	50/60 Hz	0= Ai1 0-10V	3 s	3 s
1 = Pump drive	V*	50/60 Hz	1,1 x I <sub>NMOT</sub>	0= Not used	I/O	0= Ramp	1= Ramp	20 Hz	50/60 Hz	0= Ai1 0-10V	5 s	5 s
2 = Fan drive	V*	50/60 Hz	1,1 x I <sub>NMOT</sub>	0= Not used	I/O	0= Ramp	0= Coast.	20 Hz	50/60 Hz	0= Ai1 0-10V	20 s	20 s
3 = Conveyor drive	V*	50/60 Hz	1,5 x I <sub>NMOT</sub>	1= Used	I/O	0= Ramp	0= Coast.	0 Hz	50/60 Hz	0= Ai1 0-10V	1 s	1 s

\*Same as drive voltage, except in 115V drives this value is 230V

## Parameters affected:

P1.1 Motor Un (V)	P2.3 Stop function
P1.2 Motor fn (Hz)	P3.1 Min frequency
P1.7 Current limit (A)	P3.2 Max frequency
P1.15 Torque boost	P3.3 I/O reference
P2.1 Control place	P4.2 Acc. time (s)
P2.2 Start function	P4.3 Dec time (s)

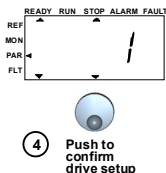

Figure 9.18: Drive setup

## 9.12 Modbus RTU

Vacon 10 has a built-in Modbus RTU bus interface. The signal level of the interface is in accordance with the RS-485 standard.

The built-in Modbus connection of Vacon 10 supports the following function codes:

Function code	Function name	Address	Broadcast messages
03	Read Holding Registers	All ID numbers	No
04	Read Input Registers	All ID numbers	No
06	Preset Single Registers	All ID numbers	Yes

### 9.12.1 Termination resistor

The RS-485 bus is terminated with termination resistors of 120 ohms in both ends. Vacon 10 has a built-in termination resistor which is switched off as a default (presented below). The termination resistor can be switched on and off with the right hand dip switch located above IO-terminals in the front of the drive (see below).

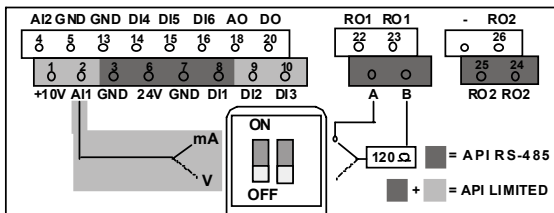

### 9.12.2 Modbus address area

The Modbus interface of Vacon 10 uses the ID numbers of the application parameters as addresses. The ID numbers can be found in the parameter tables in chapter 8. When several parameters/monitoring values are read at a time, they must be consecutive. 11 addresses can be read and the addresses can be parameters or monitoring values.



### 9.12.3 Modbus process data

Process data is an address area for fieldbus control. Fieldbus control is active when the value of parameter 2.1 (Control place) is 3 (=fieldbus). The contents of the process data has been determined in the application. The following tables present the process data contents in the General Purpose Application.

Table 9.3: Output process data:

ID	Modbus register	Name	Scale	Type
2101	32101, 42101	FB Status Word	-	Binary coded
2102	32102, 42102	FB General Status Word	-	Binary coded
2103	32103, 42103	FB Actual Speed	0,01	%
2104	32104, 42104	Motor freq.	0,01	+/- Hz
2105	32105, 42105	Motor speed	1	+/- Rpm
2106	32106, 42106	Motor current	0,01	A
2107	32107, 42107	Motor torque	0,1	+/- % (of nominal)
2108	32108, 42108	Motor power	0,1	+/- % (of nominal)
2109	32109, 42109	Motor voltage	0,1	V
2110	32110, 42110	DC voltage	1	V
2111	32111, 42111	Active fault	-	Fault code

Table 9.4: Input process data:

ID	Modbus register	Name	Scale	Type
2001	32001, 42001	FB Control Word	-	Binary coded
2002	32002, 42002	FB General Control Word	-	Binary coded
2003	32003, 42003	FB Speed Reference	0,01	%
2004	32004, 42004	PI Control Reference	0,01	%
2005	32005, 42005	PI Actual value	0,01	%
2006	32006, 42006	-	-	-
2007	32007, 42007	-	-	-
2008	32008, 42008	-	-	-
2009	32009, 42009	-	-	-
2010	32010, 42010	-	-	-
2011	32011, 42011	-	-	-

*Status word (output process data)*

Information about the status of the device and messages is indicated in the Status word. The Status word is composed of 16 bits the meanings of which are described in the table below:

Bit	Description	
	Value = 0	Value = 1
B0, RDY	Drive not ready	Drive ready
B1, RUN	Stop	Run
B2, DIR	Clockwise	Counter-clockwise
B3, FLT	No fault	Fault active
B4, W	No alarm	Alarm active
B5, AREF	Ramping	Speed reference reached
B6, Z	-	Drive is running at zero speed
B7, F	-	Flux ready
B8 - B15	-	-

*Actual speed (output process data)*

This is actual speed of the frequency converter. The scaling is -10000...10000. The value is scaled in percentage of the frequency area between set minimum and maximum frequency.

*Control word (input process data)*

The three first bits of the control word are used to control the frequency converter. By using control word it is possible to control the operation of the drive. The meaning of the bits of control word are explained in the table below:

Bit	Description	
	Value = 0	Value = 1
B0, RUN	Stop	Run
B1, DIR	Clockwise	Counter-clockwise
B2, RST	Rising edge of this bit will reset active fault	

*Speed reference (input process data)*

This is the Reference 1 to the frequency converter. Used normally as Speed reference. The allowed scaling is 0...10000. The value is scaled in percentage of the frequency area between the set minimum and maximum frequencies.

## 10. TECHNICAL DATA

## 10.1 Vacon 10 technical data

<b>Mains connection</b>	Input voltage $U_{in}$	115V, -15%...+10% 1- 208...240V, -15%...+10% 1- 208...240V, -15%...+10% 3- 380 - 480V, -15%...+10% 3- 575V, -15%...+10% 3-
	Input frequency	45...66 Hz
	Line current THD	> 120%
	Connection to mains	Once per minute or less (normal case)
<b>Supply network</b>	Networks	Vacon 10 (400V) cannot be used with corner grounded networks
	Short circuit current	Maximum short circuit current has to be < 50kA
<b>Motor connection</b>	Output voltage	0 - $U_{in}$
	Output current	Continuous rated current $I_N$ at ambient temperature max. +50°C (depends on the unit size), overload 1.5 x $I_N$ max. 1min/10min
	Starting current / torque	Current 2 x $I_N$ for 2 secs in every 20 sec period. Torque depends on motor
	Output frequency	0...320 Hz
	Frequency resolution	0,01 Hz
<b>Control characteristics</b>	Control method	Frequency Control U/f Open Loop Sensorless Vector Control
	Switching frequency	1,5...16 kHz; Factory default 6 kHz
	Frequency reference	Resolution 0.01 Hz
	Field weakening point	30...320 Hz
	Acceleration time	0.1...3000 sec
	Deceleration time	0.1...3000 sec
	Braking torque	100%* $T_N$ with brake option (only in 3- drives sizes MI2 and MI3) 30%* $T_N$ without brake option

Table 10.1: Vacon 10 technical data

<b>Ambient conditions</b>	Ambient operating temperature	-10°C (no frost)...+40/50°C (depends on the unit size): rated loadability I <sub>N</sub>
	Storage temperature	-40°C...+70°C
	Relative humidity	0...95% RH, non-condensing, non-corrosive, no dripping water
	Air quality: - chemical vapours - mech. particles	IEC 721-3-3, unit in operation, class 3C2 IEC 721-3-3, unit in operation, class 3S2
	Altitude	100% load capacity (no derating) up to 1000m. 1% derating for each 100m above 1000m; max. 2000m
	Vibration: EN60068-2-6	3...150 Hz Displacement amplitude 1(peak) mm at 3...15.8 Hz Max acceleration amplitude 1 G at 15.8...150 Hz
	Shock IEC 68-2-27	UPS Drop Test (for applicable UPS weights) Storage and shipping: max 15 G, 11 ms (in package)
	Enclosure class	IP20
	Pollution degree	PD2
<b>EMC</b>	Immunity	Complies with EN50082-1, -2, EN61800-3
	Emissions	115V: Complies with EMC category C4 230V : Complies with EMC category C2; With an internal RFI filter 400V: Complies with EMC category C2; With an internal RFI filter 575V: Complies with EMC category C4 All: No EMC emission protection (Vacon level N): Without RFI filter
<b>Standards</b>		For EMC: EN61800-3, For safety: UL508C, EN61800-5
<b>Certificates and manufacturer's declarations of conformity</b>		For safety: CB, CE, UL, cUL, For EMC: CE, CB, c-tick (see unit nameplate for more detailed approvals)

Table 10.1: Vacon 10 technical data

## 10.2 Power ratings

## 10.2.1 Vacon 10 - Mains voltage 115 V

Mains voltage 115 V, 50/60 Hz, 1~ series						
Frequency converter type	Rated loadability		Motor shaft power	Nominal input current	Mechanical size	Weight (kg)
	100% contin. current $I_N$ [A]	150% overload current [A]	P [HP]	[A]		
0001	1,7	2,6	0.33	9,2	MI2	0,70
0002	2,4	3,6	0.5	11,6	MI2	0,70
0003	2,8	4,2	0.75	12,4	MI2	0,70
0004	3,7	5,6	1	15	MI2	0,70
0005	4,8	7,2	1.5	16,5	MI3	0,99

Table 10.2: Vacon 10 power ratings, 115 V

## 10.2.2 Vacon 10 - Mains voltage 208 - 240 V

Mains voltage 208-240 V, 50/60 Hz, 1~ series						
Frequency converter type	Rated loadability		Motor shaft power	Nominal input current	Mechanical size	Weight (kg)
	100% contin. current $I_N$ [A]	150% overload current [A]	P [kW]	[A]		
0001	1,7	2,6	0,25	4,2	MI1	0,55
0002	2,4	3,6	0,37	5,7	MI1	0,55
0003	2,8	4,2	0,55	6,6	MI1	0,55
0004	3,7	5,6	0,75	8,3	MI2	0,70
0005	4,8	7,2	1,1	11,2	MI2	0,70
0007	7,0	10,5	1,5	14,1	MI2	0,70
0009	9,6	14,4	2,2	22,1	MI3	0,99

Table 10.3: Vacon 10 power ratings, 208 - 240 V, 1~

Mains voltage 208-240 V, 50/60 Hz, 3~ series						
Frequency converter type	Rated loadability		Motor shaft power	Nominal input current	Mechanical size	Weight (kg)
	100% contin. current $I_N$ [A]	150% overload current [A]	P [kW]	[A]		
0001	1,7	2,6	0,25	2,7	MI1	0,55
0002	2,4	3,6	0,37	3,5	MI1	0,55
0003	2,8	4,2	0,55	3,8	MI1	0,55
0004	3,7	5,6	0,75	4,3	MI2	0,70
0005	4,8	7,2	1,1	6,8	MI2	0,70
0007	7,0	10,5	1,5	8,4	MI2	0,70
0011	11	16,5	2,2	13,4	MI3	0,99

Table 10.4: Vacon 10 power ratings, 208 - 240 V, 3~

### 10.2.3 Vacon 10 - Mains voltage 380 - 480 V

Mains voltage 380-480 V, 50/60 Hz, 3~ series						
Frequency converter type	Rated loadability		Motor shaft power	Nominal input current	Mechanical size	Weight (kg)
	100% continuous current $I_N$ [A]	150% over-load current [A]	380-480V supply P [kW]	[A]		
0001	1,3	2,0	0,37	2,2	MI1	0,55
0002	1,9	2,9	0,55	2,8	MI1	0,55
0003	2,4	3,6	0,75	3,2	MI1	0,55
0004	3,3	5,0	1,1	4,0	MI2	0,70
0005	4,3	6,5	1,5	5,6	MI2	0,70
0006	5,6	8,4	2,2	7,3	MI2	0,70
0008	7,6	11,4	3,0	9,6	MI3	0,99
0009	9,0	13,5	4,0	11,5	MI3	0,99
0012	12,0	18,0	5,5	14,9	MI3	0,99

Table 10.5: Vacon 10 power ratings, 380 - 480 V

## 10.2.4 Vacon 10 - Mains voltage 575 V

Mains voltage 575 V, 50/60 Hz, 3~ series						
Frequency converter type	Rated loadability		Motor shaft power P [ HP ]	Nominal input current [ A ]	Mechanical size	Weight (kg)
	100% contin. current $I_N$ [ A ]	150% overload current [ A ]				
0002	1,7	2,6	1	2	MI3	0,99
0003	2,7	4,2	2	3,6	MI3	0,99
0004	3,9	5,9	3	5	MI3	0,99
0006	6,1	9,2	5	7,6	MI3	0,99
0009	9	13,5	7,5	10,4	MI3	0,99
0011	11	16,5	10	14,1	MI3	0,99

Table 10.6: Vacon 10 power ratings, 575 V

**Note 1:** The input currents are calculated values with 100 kVA line transformer supply.

**Note 2:** The mechanical dimensions of the units are given in Chapter 3.1.1.

## 10.3 Brake resistors

Vacon 10 type	Minimum braking resistance	Resistor type code (from Vacon NX family)		
		Light duty	Heavy duty	Resistance
MI2 380-480V	75 Ohm	-	-	-
MI3 380-480V	54 Ohm	BRR 0022 LD 5	BRR 0022 HD 5	63 Ohm
MI2 204-240V, 3~	35 Ohm	BRR 0022 LD 5	BRR 0022 HD 5	63 Ohm
MI3 204-240V, 3~	26 Ohm	BRR 0022 LD 5	BRR 0022 HD 5	63 Ohm
MI3 575V	Contact the manufacturer for data!			

**Note!** Only 3-phase MI2 and MI3 drives are equipped with brake chopper.

For further information on brake resistors, please download Vacon NX Brake Resistor Manual (UD00971C) on <http://www.vacon.com/Support & Downloads>

# VACON

DRIVEN BY DRIVES

Find your nearest Vacon office  
on the Internet at:

[www.vacon.com](http://www.vacon.com)

